

Agilent E5053A Microwave Downconverter

Service Guide

Second Edition



Manufacturing No. E5053-90110

December 2006

Notices

The information contained in this document is subject to change without notice.

This document contains proprietary information that is protected by copyright. All rights are reserved. No part of this document may be photocopied, reproduced, or translated to another language without the prior written consent of Agilent Technologies.

Microsoft®, MS-DOS®, Windows®, Visual C++®, Visual Basic®, VBA® and Excel® are registered

UNIX is a registered trademark in U.S. and other countries, licensed exclusively through X/Open Company Limited.

Portions ©Copyright 1996, Microsoft Corporation. All rights reserved.

© Copyright 2005, 2006 Agilent Technologies

Manual Printing History

The manual's printing date and part number indicate its current edition. The printing date changes when a new edition is printed. (Minor corrections and updates that are incorporated at reprint do not cause the date to change.) The manual part number changes when extensive technical changes are incorporated.

August 2005 First Edition

December 2006 Second Edition

Safety Summary

The following general safety precautions must be observed during all phases of operation, service, and repair of this instrument. Failure to comply with these precautions or with specific WARNINGS elsewhere in this manual may impair the protection provided by the equipment. Such noncompliance would also violate safety standards of design, manufacture, and intended use of the instrument. Agilent Technologies assumes no liability for the customer's failure to comply with these precautions.

NOTE

The E5053A complies with INSTALLATION CATEGORY II as well as POLLUTION DEGREE 2 in IEC61010-1. The E5053A is an INDOOR USE product.

NOTE

The LEDs in the E5053A are Class 1 in accordance with IEC60825-1, CLASS 1 LED PRODUCT

NOTE

This equipment is MEASUREMENT CATEGORY I (CAT I). Do not use for CAT II, III, or IV.

NOTE

This equipment is tested with stand-alone condition or with the combination with the accessories supplied by Agilent Technologies against the requirement of the standards described in the Declaration of Conformity. If it is used as a system component, compliance of related regulations and safety requirements are to be confirmed by the builder of the system.

- Ground the Instrument

To avoid electric shock, the instrument chassis and cabinet must be grounded with the supplied power cable's grounding prong.

- DO NOT Operate in an Explosive Atmosphere

Do not operate the instrument in the presence of inflammable gasses or fumes. Operation of any electrical instrument in such an environment clearly constitutes a safety hazard.

- Keep Away from Live Circuits

Operators must not remove instrument covers. Component replacement and internal adjustments must be made by qualified maintenance personnel. Do not replace components with the power cable connected. Under certain conditions, dangerous voltage levels may remain even after the power cable has been disconnected. To avoid injuries, always disconnect the power and discharge circuits before touching them.

- DO NOT Service or Adjust the Instrument Alone

Do not attempt internal service or adjustment unless another person, capable of rendering first aid and resuscitation, is present.

- DO NOT Substitute Parts or Modify the Instrument

To avoid the danger of introducing additional hazards, do not install substitute parts or perform unauthorized modifications to the instrument. Return the instrument to an Agilent Technologies Sales and Service Office for service and repair to ensure that safety features are maintained in operational condition.

- Dangerous Procedure Warnings

Warnings, such as the example below, precede potentially dangerous procedures throughout this manual. Instructions contained in the warnings must be followed.









WARNING

Dangerous voltage levels, capable of causing death, are present in this instrument. Use extreme caution when handling, testing, and adjusting this instrument.

- Do not connect the measuring terminals to mains.

Safety Symbols

General definitions of safety symbols used on the instrument or in manuals are listed below.

-  Instruction Manual symbol: the product is marked with this symbol when it is necessary for the user to refer to the instrument manual.
-  Alternating current.
-  Direct current.
-  On (Supply).
-  Off (Supply).
-  In position of push-button switch.
-  Out position of push-button switch.
-  Frame (or chassis) terminal. A connection to the frame (chassis) of the equipment which normally include all exposed metal structure.
-  Stand-by.

WARNING This warning sign denotes a hazard. It calls attention to a procedure, practice, condition or the like, which, if not correctly performed or adhered to, could result in injury or death to personnel.

CAUTION This Caution sign denotes a hazard. It calls attention to a procedure, practice, condition or the like, which, if not correctly performed or adhered to, could result in damage to or destruction of part or all of the product.

NOTE Note denotes important information. It calls attention to a procedure, practice, condition or the like, which is essential to highlight.

Certification

Agilent Technologies certifies that this product met its published specifications at the time of shipment from the factory. Agilent Technologies further certifies that its calibration measurements are traceable to the United States National Institute of Standards and Technology, to the extent allowed by the Institution's calibration facility, or to the calibration facilities of other International Standards Organization members.

Documentation Warranty

The material contained in this document is provided "as is," and is subject to being changed, without notice, in future editions. Further, to the maximum extent permitted by applicable law, Agilent disclaims all warranties, either express or implied with regard to this manual and any information contained herein, including but not limited to the implied warranties of merchantability and fitness for a particular purpose. Agilent shall not be liable for errors or for incidental or consequential damages in connection with the furnishing, use, or performance of this document or any information contained herein. Should Agilent and the user have a separate written agreement with warranty terms covering the material in this document that conflict with these terms, the warranty terms in the separate agreement will control.

Exclusive Remedies

The remedies provided herein are buyer's sole and exclusive remedies. Agilent Technologies shall not be liable for any direct, indirect, special, incidental, or consequential damages, whether based on contract, tort, or any other legal theory.

Assistance

Product maintenance agreements and other customer assistance agreements are available for Agilent Technologies products.

For any assistance, contact your nearest Agilent Technologies Sales and Service Office. Addresses are provided at the back of this manual.

Typeface Conventions

Sample (bold)	Boldface type is used when a term is defined or emphasised.
<i>Sample (Italic)</i>	Italic type is used for emphasis.
Sample key / [Sample] key	Indicates a hardkey (key on the front panel or external keyboard) labeled “Sample.” “key” may be omitted.
Sample menu/button/box	Indicates a menu/button/box on the screen labeled “Sample” which can be selected/executed by clicking. “menu,” “button,” or “box” may be omitted.
Sample block/toolbar	Indicates a block (group of hardkeys) or a toolbar (setup toolbar) labeled “Sample.”
Sample 1 - Sample 2 - Sample 3	Indicates a sequential operation of Sample 1 , Sample 2 , and Sample 3 (menu, button, or box). “-” may be omitted.

1. General Information	
Organization of Service Guide	12
Instrument Covered by This Manual	13
Required Equipment	14
2. Performance Tests	
Introduction	18
Test Equipment Required	18
Individual Test Description	19
1. LOCAL Output Frequency Accuracy Test	19
2. LOCAL Output Level Accuracy Test	20
3. Mixer Bias Output Current Accuracy Test	21
4. LOCAL Phase Noise Sensitivity Test	22
3. Adjustment	
Safety Considerations	26
Warm-up for Adjustment	26
Required Equipment	26
Required Adjustment after Replacing Assembly	27
Writing ID	27
VCXO Adjustment	28
OCXO Adjustment	28
Pretune Adjustment	28
Sampler RF Adjustment	28
Outpur Level Adjustment	29
IF Path Adjustment	29
IF Gain Adjustment	29
Thru Path Adjustment	29
Mixer IF Adjustment	30
Mixer RF Adjustment	30
Level Monitor Adjustment	31
Current Source Adjustment	31
4. Troubleshooting	
Introduction	34
To Troubleshoot the Instrument	35
Primary Trouble Isolation	35
Power Supply Troubleshooting	37
Check the Line Voltage and Fuse	37
Check the Power Supply Unit Output	37
Check the voltages on the A12 board	38
Troubleshooting Using Service Function	40
E5053 Test	40
Contents of the power on test results	41
E5053 Test Failure Troubleshooting	43
Performance test failure troubleshooting	44
Recommended adjustment for performance test failure	44
Adjustment failure troubleshooting	45

Performance test failure troubleshooting	46
5. Replaceable Parts	
Ordering Information	50
Direct Mail Order System	50
Exchange Assemblies	50
Replaceable Parts List	51
Power Cables and Plug Configurations	51
Top View (Major Assemblies)	52
Top View (Cables)	54
Top View (Miscellaneous Parts)	56
Bottom View (Major Assembly/Cables)	58
Bottom View (Miscellaneous Parts)	59
Top/Front View (Cables)	60
Front View (Miscellaneous Parts)	61
Rear View	62
Cover Assembly	64
OCXO Assembly	66
Front Panel Assembly	68
Front Panel Rear Assembly	70
YIG Assembly	72
Fan Assembly	73
PS Wire Assembly	74
Other Parts	76
6. Replacement Procedure	
Replacing an Assembly	78
Required Tools	79
Outer Cover Removal	80
Tools Required	80
Removal Procedure	80
Replacement Procedure	80
Front Assembly Removal	82
Tools required	82
Removal Procedure	82
Replacement Procedure	82
Switch Wire Assembly Replacement	84
Tools required	84
Removal Procedure	84
Replacement Procedure	84
RF In Connector Replacement	86
Tools required	86
Removal Procedure	86
Replacement Procedure	86
Mixer Replacement	88
Tools required	88
Removal Procedure	88
Replacement Procedure	88

Power Divider Replacement	90
Tools required	90
Removal Procedure	90
Replacement Procedure.	90
SMA Connector Replacement	92
Tools required	92
Removal Procedure	92
Replacement Procedure.	92
Panel Front Replacement	94
Tools required	94
Removal Procedure	94
A4/A14 YIG PLL Board Replacement.	96
Tools Required	96
Removal Procedure	96
Replacement Procedure.	96
A5/A15 Reference PLL Board Replacement	98
Tools Required	98
Removal procedure	98
Replacement Procedure.	98
A6 Receiver Board Replacement	100
Tools Required	100
Removal Procedure	100
Replacement Procedure.	100
A12 PIS DIGIFUL I/F Board Replacement	102
Tools Required	102
Removal Procedure	102
Replacement Procedure.	102
OCXO Assembly Replacement	104
Tools Required	104
Removal Procedure	104
Replacement Procedure.	104
YTO (YIG Tuned Oscillator) Assembly Replacement.	106
Tools Required	106
Removal Procedure	106
Replacement Procedure.	106
Power Supply Assembly Replacement.	108
Tools Required	108
Removal Procedure	108
Replacement Procedure.	108
Inlet Assembly Replacement	110
Tools Required	110
Removal Procedure	110
Replacement Procedure.	110
Fan Assembly Replacement	112
Tools Required	112
Removal Procedure	112
Replacement Procedure.	112

7. Post-Repair Procedures

Contents

Post-Repair Procedures	116
A. Manual Changes	
Manual Changes	120
B. Power Requirement	
Power Supply and Blown Fuses	122
Verification of the power supply	122
Verification and connection of power cable	122
Blown fuses	124
Starting the E5053A	125
Turning ON/OFF the power	125
Disconnection from supply source	125

1 General Information

The Service Guide is a guide to servicing the E5053A Microwave Downconverter. The guide contains information requisite to do performance tests, adjustments, troubleshooting, and repairs.

Organization of Service Guide

Tabs are used to divide the major chapter and appendix of this manual. The contents of each chapter and appendix in this manual is as follows;

Chapter 1 , “General Information,”

The Service Guide is a guide to servicing the E5053A Microwave Downconverter. The guide contains information requisite to do performance tests, adjustments, troubleshooting, and repairs.

Chapter 2 , “Performance Tests,”

This chapter provides outline of the E5053A performance tests.

Chapter 3 , “Adjustment,”

This chapter provides the adjustment information for the E5053A to ensure that it is within its specifications. The adjustment must be performed Agilent’s qualified service personnel. If you need the adjustment for your E5053A, it should be sent to the nearest Agilent Technologies service office.

Chapter 4 , “Troubleshooting,”

This chapter provides the procedure to isolate a faulty assembly in the E5053A.

Chapter 5 , “Replaceable Parts,”

This chapter contains information for ordering replacement parts for the E5053A.

Chapter 6 , “Replacement Procedure,”

This chapter provides procedure for removing and replacing the major assemblies in the E5053A.

Chapter 7 , “Post-Repair Procedures,”

This chapter lists the procedures required to verify the E5053A operation after an assembly is replaced with a new one.

Appendix A , “Manual Changes,”

This appendix contains the information required to adapt this manual to versions or configurations of the E5053A manufactured earlier than the current printing date of this manual. The information in this manual applies directly to E5053A units with the serial number that is printed on the title page of this manual.

Appendix B , “Power Requirement,”

Instrument Covered by This Manual

Agilent Technologies uses a two-part, ten-character serial number label (See Figure 1-1) attached to the instrument's rear panel. The first five characters are the serial prefix and the last five digits are the suffix.

Figure 1-1

Serial Number Label Example

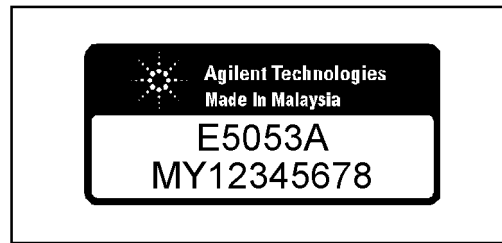

An instrument manufactured after the printing date of this manual may have serial number prefix that is not listed on the title page. This unlisted serial number prefix indicates the instrument is different from those described in this manual. The manual for this new instrument may be accompanied by a yellow Manual Changes supplement or have a different manual part number. This sheet contains “change information” that explains how to adapt the manual to the newer instrument.

In addition to change information, the supplement may contain information for correcting errors (Errata) in the manual. To keep this manual as current and accurate as possible, Agilent Technologies recommends that you periodically request the latest Manual Changes supplement. The supplement for this manual is identified by this manual's printing data and is available from Agilent Technologies. If the serial prefix or number of an instrument is lower than that on the title page of this manual, see Appendix A, Manual Changes. For information concerning a serial number prefix that is not listed on the title page or in the Manual change supplement, contact the nearest Agilent Technologies office.

Required Equipment

Table 1-1 lists the recommended equipment for performing maintenance on the E5053A.

Table 1-1 Recommended Test Equipment

Equipment	Critical specifications	Recommended Model	Qty.	Use ^{*1}
Phase Noise Test System	No Substitute	Agilent E5500	1	P
Signal Generator	Frequency: 10 MHz to 26.5 GHz Low SSB Phase Noise	Agilent E8257D W/opt. UNR	1	P,A
Network Analyzer	Frequency: 10 M to 3 GHz	Agilent E5071B	1	A
Power Meter	No Substitute	Agilent E4419B	1	P,A
Power Sensor	No Substitute	Agilent E4413A	1	P,A
Power Sensor	No Substitute	Agilent E4412A	1	A
Multimeter	No Substitute	Agilent 3458A	1	P,A
Calibration Kit	Frequency: 10 M to 3 GHz	Agilent 85033E	1	A
Frequency Counter	Frequency: 10 MHz - 12 GHz	Agilent 53181A w/Opt.010, 124	1	P,A
Spectrum Analyzer	Frequency: 10 MHz - 15 GHz	Agilent E4440A	1	A
Fixed attenuator (10 dB)	50 Ω , SMA(m)-SMA(f), 10 dB	Agilent 8493C Opt.010	1	P,A
Power Splitter	SMA(f) 50 Ω in, SMA(f) 50 Ω out	Agilent 11667B	1	P,A
50 Ω Termination	50 Ω SMA(m)	Agilent p/n 1810-0118	3	P,A
Cable	BNC(m)-BNC(m) Cable, 61 cm	Agilent p/n 8120-1839	1	P,A
	SMA(m)-SMA(m) Cable, 61 cm	Agilent 11500E	2	P,A
	SMA(m)-SMA(m), 61 cm (9 in)	Agilent p/n 5062-6684	1	P
Adapter	N(m)-SMA(f) Adapter	Agilent p/n 1250-1250	1	P,A
	BNC(m)-SMA(f) Adapter	Agilent p/n 1250-2015	1	P,A
	APC-7-SMA(f) Adapter	Agilent p/n 1250-1747	1	P,A
	N(f)-SMA(m) Adapter	Agilent p/n 1250-1562	1	A
	Dual Banana-BNC(f)	Agilent p/n 1251-2277	1	P,A
Torque Wrench	Size: 3/4 inch Torque: 136 N-cm	Agilent p/n 8710-1766	1	P,A

Table 1-1 Recommended Test Equipment

Equipment	Critical specifications	Recommended Model	Qty.	Use ^{*1}
Personal Computer with GPIB board	Windows 2000/XP, VEE 6.2		1	P,A

*1. P: Performance Tests, A: Adjustment, T: Troubleshooting

Table 1-2 Alternative Test Equipment

Equipment	Critical specifications	Model	Qty.	Use ^{*1}
Signal Generator	Frequency: 10 MHz to 7 GHz Low SSB Phase Noise	Agilent E8257C w/Opt. UNR	1	P,A
Network Analyzer	Frequency: 10 M to 3 GHz	Agilent 8753ES	1	A
Power Meter	No Substitute	Agilent E4419A	1	P,A
Multimeter	No Substitute	Agilent 34401A	1	P,A
Spectrum Analyzer	Frequency: 10 MHz to 15 GHz	Agilent E4408B	1	A
Signal Source Analyzer	No Substitute	Agilent E5052A	1	P

*1. P: Performance Tests, A: Adjustment, T: Troubleshooting

General Information
Required Equipment

2 Performance Tests

This chapter provides outline of the E5053A performance tests.

Introduction

This chapter provides the performance tests outline for Agilent E5053A. The performance test names are listed in Table 2-1. The test procedures are described sequentially in the following pages.

NOTE Allow the analyzer to warm up for at least 30 minutes before you execute any of the performance tests.

Perform all performance tests in an ambient temperature of 23 ± 5 °C

NOTE The performance tests should be performed periodically. The recommended test interval is 12 months.

The test interval depends on maintenance and the environmental conditions under which the instrument is used. You may find that the interval could be shortened or lengthened; however, such a decision should be based on substantial quantitative data.

Table 2-1 List of the E5053A performance tests

Para.	Title
1	LOCAL Output Frequency Accuracy Test
2	LOCAL Output Level Accuracy Test
3	Mixer Bias Output Current Accuracy Test
4	LOCAL Phase Noise Sensitivity Test

Test Equipment Required

The required equipment for the performance test is listed in Table 1-1 and Table 1-2. Use only calibrated equipment when doing the performance test.

Individual Test Description

1. LOCAL Output Frequency Accuracy Test

Description

This test checks the frequency accuracy of the E5053A LO_Out port output signal.

Specification

@23 ± 5 °C

Frequency Accuracy < ± 10 ppm @ 3.025 GHz to 10.025 GHz

Test equipment

Frequency Counter	Agilent 53181A with Opt. 010 and 124
10 dB Attenuator SMA	Agilent 8493C Option 010
N(m)-SMA(f) Adapter	Agilent p/n 1250-1250
SMA(m)-SMA(m) Cable, 61cm	Agilent 11500E

Test point and limits

@ Level: 15 dBm

Frequency [Hz]	Test limit [Hz]	Measurement uncertainty [Hz]
3.025 G	± 30250	± 349
5.025 G	± 50250	± 588
7.025 G	± 70250	± 822
10.025 G	± 100250	± 1174

2. LOCAL Output Level Accuracy Test

Description

This test checks the level accuracy of the E5053A LO_Out port output signal.

Specification

@23 ± 5 °C

Level accuracy	± 2 dB
	10 to 16 dBm @ 3.025 GHz to 6.025 GHz
	10 to 15 dBm @ 6.075 GHz to 10.025 GHz

Test equipment

Power Meter	Agilent E4419B
Power Sensor	Agilent E4413A
N(m)-SMA(f) Adapter	Agilent p/n 1250-1250

Test point and limits

@ Level: 10 dBm

Frequency [Hz]	Test limit [dB]	Measurement uncertainty [dB]
3.025 G	± 2.0	± 0.41
6.025 G	± 2.0	± 0.44
10.025 G	± 2.0	± 0.44

@ Level: 16 dBm

Frequency [Hz]	Test limit [dB]	Measurement uncertainty [dB]
3.025 G	± 2.0	± 0.41

@ Level: 15 dBm

Frequency [Hz]	Test limit [dB]	Measurement uncertainty [dB]
6.025 G	± 2.0	± 0.44
10.025 G	± 2.0	± 0.44

3. Mixer Bias Output Current Accuracy Test

Description

This test checks the current accuracy of the E5053A IF_In port.

Specification

@ 23 ± 5 °C

Current Accuracy $\pm (10 \% + 0.1 \text{ mA})$ @ -10 mA to + 10 mA

Test equipment

DVM	Agilent 3458A
Dual Banana-BNC(f) adapter	Agilent p/n 1251-2277
BNC(m)-SMA(f) Adapter	Agilent p/n 1250-2015
SMA(m)-SMA(m) Cable, 61 cm	Agilent 11500E
Termination SMA(m), 2ea	Agilent p/n 1810-0118

Test point and limits

Current [mA]	Test limit [mA]	Measurement uncertainty [μ A]
- 10	± 1.1	± 20.7
0	± 0.1	± 1.5
10	± 1.1	± 19.1

4. LOCAL Phase Noise Sensitivity Test

Description

This test checks the phase noise sensitivity of the E5053A LO_Out port output signal.

Specification

@23 ± 5 °C

Local Phase Noise sensitivity [dBc/Hz]

Input Frequency	Offset from carrier (Hz)					
	1 k	10 k	100 k	1 M	10 M	40 M
3 GHz	-110.5	-116.5	-113.5	-127.5	-140.0	-140.0
6 GHz	-104.4	-110.4	-109.4	-123.4	-140.0	-140.0
10 GHz	-100.0	-103.0	-102.0	-119.0	-140.0	-140.0

Test equipment

Phase Noise Test System	E5500
Analog Signal Generator	E8257D with Opt. UNR
10 dB Attenuator SMA	8493C Option 010
SMA(m)-SMA(m) Cable, 9 inch	Agilent p/n 5062-6684
N(m)-SMA(f) Adapter	Agilent p/n 1250-1250
SMA(m)-SMA(m) cable, 61cm.	Agilent 11500E
Termination SMA(m)	Agilent p/n 1818-0118

Test point and limits

@ Frequency: 3.325 GHz, Level: 15 dBm

Offset Frequency [Hz]	Test limit [dBc/Hz]
1 k	< -109.6
10 k	< -115.6
100 k	< -112.6
1 M	< -126.6
10 M	< -140.0
40 M	< -140.0

@ Frequency: 5.675 GHz, Level: 15 dBm

Offset Frequency [Hz]	Test limit [dBc/Hz]
1 k	< -104.9
10 k	< -110.9
100 k	< -109.9
1 M	< -123.9
10 M	< -140.0
40 M	< -140.0

@ Frequency: 10.025 GHz, Level: 15 dBm

Offset Frequency [Hz]	Test limit [dBc/Hz]
1 k	< -100.0
10 k	< -103.0
100 k	< -102.0
1 M	< -119.0
10 M	< -140.0
40 M	< -140.0

Performance Tests
Individual Test Description

3 Adjustment

This chapter provides the adjustment information for the E5053A to ensure that it is within its specifications. The adjustment must be performed Agilent's qualified service personnel. If you need the adjustment for your E5053A, it should be sent to the nearest Agilent Technologies service office.

Safety Considerations

This manual contains NOTES, CAUTIONs, and WARNINGs that must be followed to ensure the safety of the operator and to keep the instrument in a safe and serviceable condition. The adjustment must be performed by Agilent's qualified service personnel.

WARNING

Any interruption of the protective ground conductor (inside or outside the equipment) or disconnection of the protective ground terminal can make the instrument dangerous. Intentional interruption of the protective ground system for any reason is prohibited.

Warm-up for Adjustment

Warm-up the E5053A for at least 30 minute before performing any of the following Adjustment procedures to ensure proper results and correct instrument operation.

Required Equipment

Table 1-1 on page 14 lists the equipment required to perform the Adjustment procedures described in this chapter. Use only calibrated test equipment when adjusting the E5053A.

Required Adjustment after Replacing Assembly

After replacing the following assembly, the adjustment items described in Table 3-1 must be required. The adjustment must be performed Agilent's qualified service personnel. If you need the adjustment for your E5053A, it should be sent to the nearest Agilent Technologies service office.

Table 3-1 Required Adjustment Item after Replacing Assembly

Replaced Assembly	Adjustment Item																		
	Writing ID	VCXO Adjustment (Ch 1)	VCXO Adjustment (Ch 2)	OCXO Adjustment (Ch 1)	OCXO Adjustment (Ch 2)	Pretune Adjustment (Ch 1)	Pretune Adjustment (Ch 2)	Sampler RF Adjustment (Ch 1)	Sampler RF Adjustment (Ch 2)	Output Level Adjustment (Ch 1)	Output Level Adjustment (Ch 2)	IF Path Adjustment	IF Gain Adjustment	Thru Path Adjustment	Mixer RF Adjustment	Mixer IF Adjustment	Level Monitor	Current Source Adjustment	
OCXO (Ch 1)				√															
OCXO (Ch 2)					√														
YIG (Ch 1)						√		√		√					√	√			
YIG (Ch 2)							√		√		√				√	√			
A4 YIG PLL						√		√		√					√	√			
A14 YIG PLL							√		√		√				√	√			
A5 REF PLL		√						√											
A15 REF PLL			√						√										
A6 RECEIVER												√	√	√	√	√	√	√	√
A12 PIS	√			√	√												√		
Mixer (Ch 1)															√	√			
Mixer (Ch 2)															√	√			
Divider															√	√			
11742A															√	√			
3 dB Attenuator															√	√			

Writing ID

This item writes the serial number, default system data, and power on test limits into the A12 of the E5053A.

Adjustment

Required Adjustment after Replacing Assembly

Required equipment for the writing ID

None

VCXO Adjustment

The purpose of this procedure is to adjust the free run frequency of A5 (or A15) board's VCXO, and to find the DAC (12 bit) value when oscillation frequency is 100 MHz (+- 0.5 ppm).

Required equipment for the VCXO adjustment

Description	Recommended Model
Frequency Counter	Agilent 53181A
BNC(m)-BNC(m) Cable, 61 cm	Agilent p/n 8120-1839

OCXO Adjustment

The purpose of this procedure is to adjust the oscillation frequency of OVEN, and to find the DAC value where CH1 frequency is 10 MHz + 0.2 ppm and CH2 is 10 MHz - 0.2 ppm.

Required equipment for the OCXO adjustment

Description	Recommended Model
Frequency Counter	Agilent 53181A
BNC(m)-BNC(m) Cable, 61 cm	Agilent p/n 8120-1839

Pretune Adjustment

The purpose of this procedure is to find the table for output frequency vs pretune DAC. In the same time, its level is also being monitored and confirm the presence oscillation.

Required equipment for the Pretune adjustment

Description	Recommended Model
Spectrum Analyzer	Agilent E4440A
Termination SMA(m)	Agilent p/n 1810-0118
SMA(m)-SMA(m) Cable, 61cm	Agilent 11500E

Sampler RF Adjustment

The purpose of this procedure is to find the 12 bit DAC value of variable Attenuator to the desired RF level in sampler RF level adjustment.

Required equipment for the Sampler RF adjustment

None.

Output Level Adjustment

The purpose of this procedure is to adjust the Local output level.

Required equipment for the Output Level adjustment

Description	Recommended Model
Power Meter	Agilent E4419B
Power Sensor	Agilent E4413A
Power Sensor	Agilent E4412A
N(f)-SMA(m) Adapter	Agilent p/n 1250-1562

IF Path Adjustment

The purpose of this procedure is to obtain correction factor for IF IN to IF OUT gain and frequency characteristic when an external mixer is used.

Required equipment for the IF Path adjustment

Description	Recommended Model
Network Analyzer	Agilent E5071B
Calibration kit	Agilent 85033E
Termination SMA(m), 3ea	Agilent p/n 1810-0118
SMA(m)-SMA(m) Cable, 61cm	Agilent 11500E
APC-7-SMA(f) Adapter	Agilent p/n 1250-1747

IF Gain Adjustment

The purpose of this procedure is to compensate for IF variable gain.

Required equipment for the IF Gain adjustment

Description	Recommended Model
Network Analyzer	Agilent E5071B
Calibration kit	Agilent 85033E
Termination SMA(m), 3ea	Agilent p/n 1818-0118
SMA(m)-SMA(m) Cable, 61cm	Agilent 11500E
APC-7-SMA(f) Adapter	Agilent p/n 1250-1747

Thru Path Adjustment

The purpose of this procedure is to compensate gain from Ch 1/2 RF IN to IF Out.

Adjustment

Required Adjustment after Replacing Assembly

Required equipment for the Thru Path adjustment

Description	Recommended Model
Network Analyzer	Agilent E5071B
Calibration kit	Agilent 85033E
Termination SMA(m), 2ea	Agilent p/n 1818-0118
SMA(m)-SMA(m) Cable, 61cm	Agilent 11500E
APC-7-SMA(f) Adapter	Agilent p/n 1250-1747

Mixer IF Adjustment

The purpose of this procedure is to adjust the mixer conversion loss on IF frequency.

Required equipment for the Mixer IF adjustment

Description	Recommended Model
Signal Generator	Agilent E8257D
Power Meter	Agilent E4419B
Power Sensor	Agilent E4413A
Power Sensor	Agilent E4412A
Power Splitter	Agilent 11667B
Termination SMA(m), 3ea	Agilent p/n 1810-0118
SMA(m)-SMA(m) Cable, 61cm	Agilent 11500E
N(m)-SMA(f) Adapter	Agilent p/n 1250-1744

Mixer RF Adjustment

The purpose of this procedure is to adjust the mixer conversion loss.

Required equipment for the Mixer RF adjustment

Description	Recommended Model
Signal Generator	Agilent E8257D
Power Meter	Agilent E4419B
Power Sensor	Agilent E4413A
Power Sensor	Agilent E4412A
Power Splitter	Agilent 11667B
Termination SMA(m), 3ea	Agilent p/n 1818-0118
SMA(m)-SMA(m) Cable, 61cm	Agilent 11500E
N(f)-SMA(m) Adapter	Agilent p/n 1250-1562

Level Monitor Adjustment

The purpose of this procedure is to adjust the IF output level monitor.

Required equipment for the Level Monitor adjustment

Description	Recommended Model
Signal Generator	Agilent E8257D
Power Meter	Agilent E4419B
Power Sensor	Agilent E4413A
Power Sensor	Agilent E4412A
Power Splitter	Agilent 11667B
Termination SMA(m), 3ea	Agilent p/n 1810-0118
SMA 10 dB PAD	Agilent 8493C option 010
SMA(m)-SMA(m) Cable, 61cm	Agilent 11500E
N(f)-SMA(m) Adapter	Agilent p/n 1250-1562

Current Source Adjustment

The purpose of this procedure is to adjust the gain and offset of the current source from IF input.

Required equipment for the Current Source adjustment

Description	Recommended Model
DVM	Agilent 3458A

Adjustment

Required Adjustment after Replacing Assembly

Description	Recommended Model
Dual Banana-BNC(f) adapter	Agilent p/n 1251-2277
BNC(m)-BNC(m) Cable, 61 cm	Agilent p/n 8120-1839
BNC(f)-SMA(m) Adapter	Agilent p/n 1250-1200
Termination SMA(m), 2ea	Agilent p/n 1810-0118

4 Troubleshooting

This chapter provides the procedure to isolate a faulty assembly in the E5053A.

Introduction

WARNING These servicing instructions are for use by qualified personnel only. To avoid possible electrical shock, do not perform any servicing unless you are qualified to do so.

WARNING The opening of covers or removal of parts is likely to expose dangerous voltages. Disconnect the instrument from its power supply beforehand.

CAUTION Many of the assemblies in the instrument are very susceptible to damage from ESD (electrostatic discharge). Perform the following procedures only at a static-safe workstation and wear a grounding strap.

CAUTION DO NOT operate without following instructions. Programs or files in the instrument may be broken.

To Troubleshoot the Instrument

This section describes the basic procedural flow of troubleshooting when servicing the E5053A. The primary procedural tool in this section is the flowchart. The flowchart contains the entire troubleshooting path from a failure symptom to the isolation of faulty assembly, and will direct you to the completion of repair in an ordinary manner through the possible failure symptoms. Reference letters (Yes/No) on the flowcharts point to procedural steps that briefly explain the troubleshooting method to be performed next.

Primary Trouble Isolation

The primary trouble isolation in Figure 4-1 is to help direct you to the correct section for troubleshooting the E5053A.

Step 1. Turn the E5053A power on

With the E5053A plugged in and the power turned off, the front panel orange standby LED should be on. When the front panel power switch is turned on, the orange LED should go out and the green LED should come on. Also, the fan should start rotating. In case of unexpected results, go to “Power Supply Troubleshooting”.

Step 2. Check the E5053A power on test with E5052A

If the E5053A power on test fails, go to “Troubleshooting Using Service Function” on page 40.

Step 3. Check the measurement function

If the E5053A fails any of the performance tests, go to “Performance test failure troubleshooting” on page 44.

A faulty part is replaced according to Chapter 5 which gives replacement procedures for the parts. The procedures required after part replacement are given in Chapter 6.

Figure 4-1

Primary trouble isolation flowchart

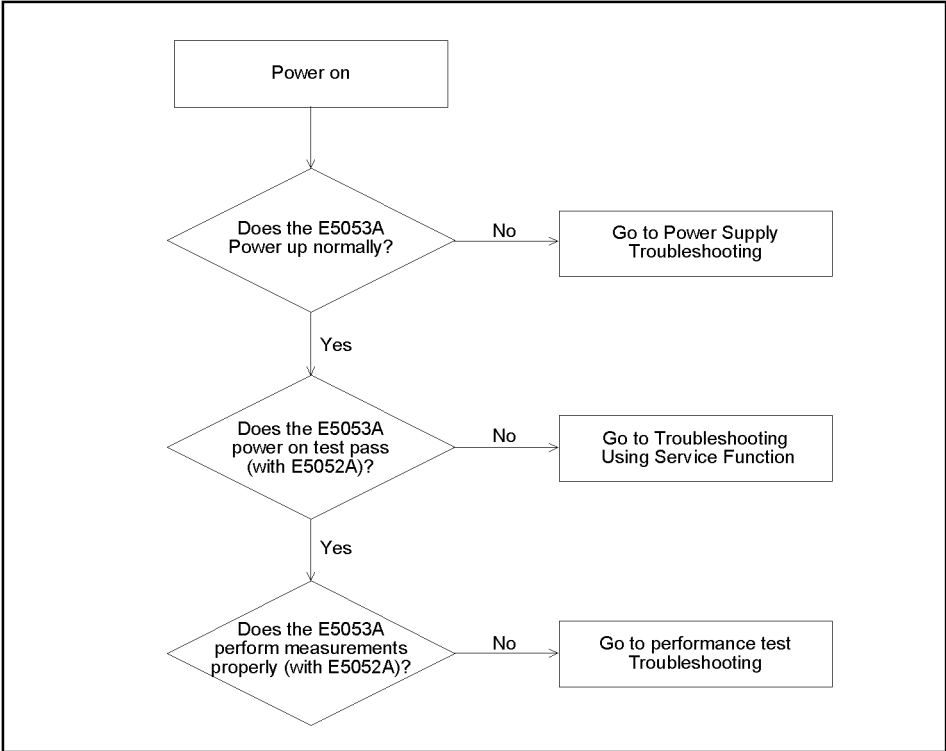

e5053ase1054

Power Supply Troubleshooting

Check the Line Voltage and Fuse

Check the main power line cord, line fuse, actual line voltage to see that they are all correct. For more information about the line cord and Line fuse, see the Power Requirements in Appendix B.

Check the Power Supply Unit Output

- Step 1.** Remove the E5053A's outer cover.
- Step 2.** Turn the E5053A power on.
- Step 3.** Measure the output voltage (+3.3, +5, +12, -12 V) of each power supply unit using a voltmeter with a small probe. The location of each voltage connector on the the A12 board is shown in Figure 4-2.

Figure 4-2 Output Voltage Location

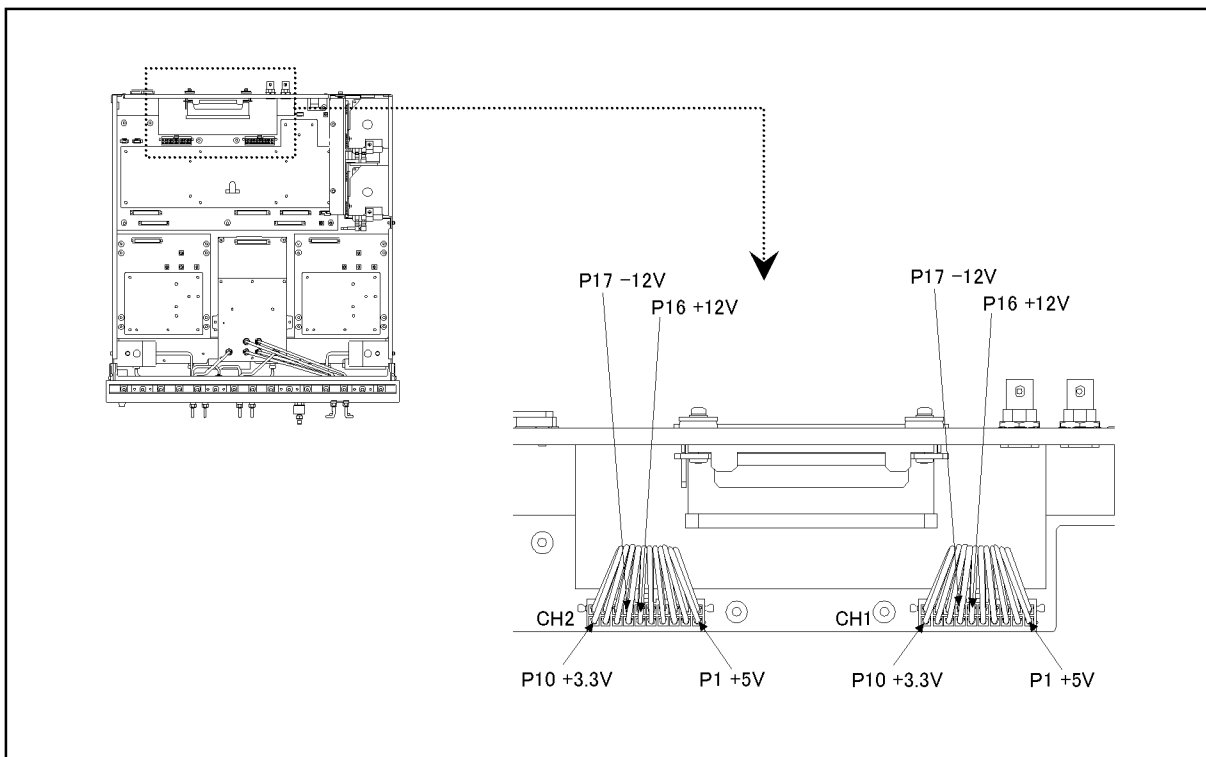

e5053ase1044

- If the voltmeter reading is not within the following limits, replace the power supply

unit.

Table 4-1 Power Supply Unit Output

supply	Range
+ 3.3 V	+ 3.2 to + 3.4
+ 5 V	+ 4.8 to + 5.2
+ 12 V	+ 11.4 to + 12.6
- 12 V	- 11.4 to -12.6

- If the voltmeter reading is within the limits, the power supply is verified.

Check the voltages on the A12 board

Step 1. Remove the shield case from the A12 board. The location of each voltage terminal is shown in Figure 4-3.

Figure 4-3 Voltage Location of the A12 board

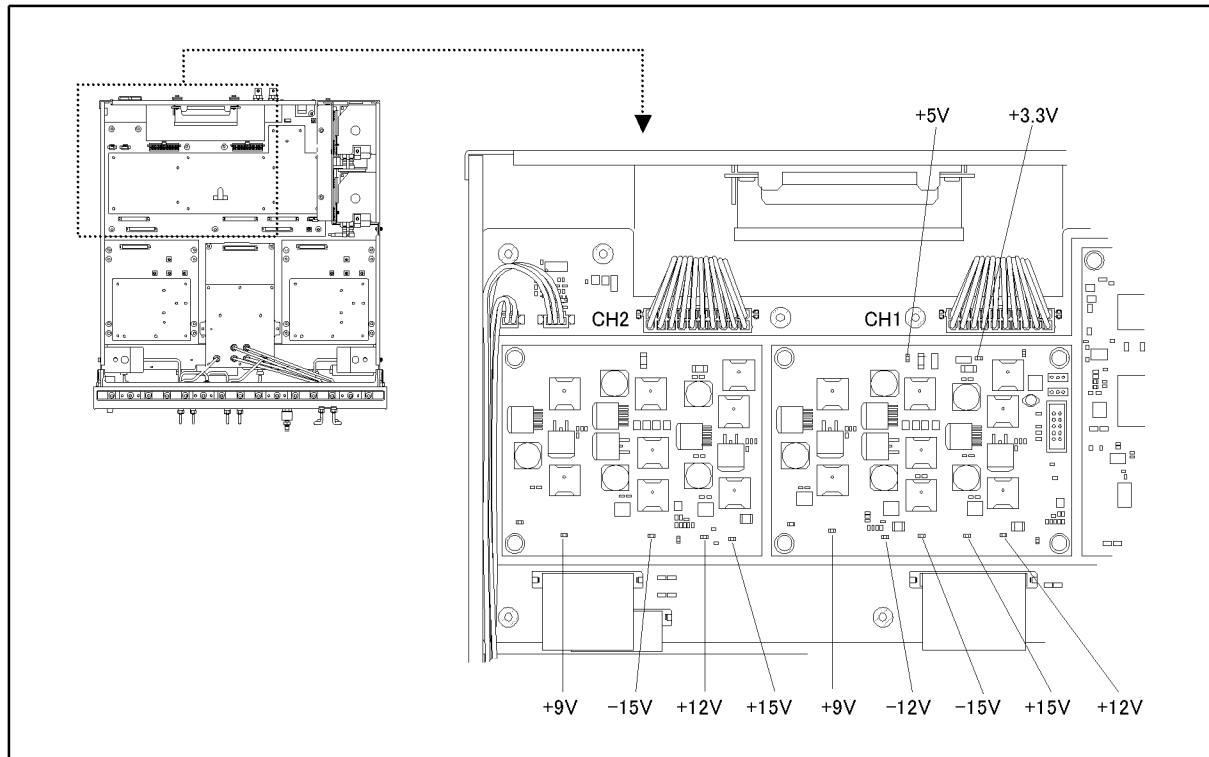

e5053ase1045

Step 2. Turn the E5053A power on.

Step 3. Measure the DC voltages on the A12 board using a voltmeter with a small probe. See Table

4-2 for power lines and limits.

Table 4-2

Output voltages of the A12 board

Supply	Range
+ 5 V CH1 (for A12 Digital)	+ 4.5 to + 5.5
+ 3.3 V CH1 (for A12 Digital)	+ 2.97 to +3.63
+ 9 V CH1 (for A4, A5)	+ 8.1 to +9.9
- 12 V CH1 (for OCXO)	- 10.8 to - 13.2
- 15 V CH1 (for A4, A5)	- 13.5 to - 16.5
+ 15 V CH1 (for A4, A5, A12, OCXO)	+ 13.5 to +16.5
+ 12 V CH1 (for FAN, OVEN)	+ 10.8 to +13.2
+ 9 V CH2 (for A14, A15)	+ 8.1 to + 9.9
- 15 V CH2 (for A14, A15)	- 13.5 to - 16.5
+ 12 V CH2 (for OVEN)	+ 10.8 to + 13.2
+ 15 V CH2 (for A14, A15, OCXO)	+ 13.5 to + 16.5

- If any of the voltages are not within these limits, replace the A12 board.
- If all the voltages are good, the A12 board is verified.

Troubleshooting Using Service Function

The Agilent E5053A has a service function to diagnose the analog measurement section and internal dc power supply voltages. By using the E5053 Test of the service function, it is possible to isolate a faulty board assembly. The following paragraphs describe the procedure to perform the E5053 Test.

E5053 Test

E5053 test always takes place once the E5053A and the E5052A are turned on. When a failure for E5053A is detected, a message "Downconverter test failed" is displayed. The content of the E5053 test includes the dc power supply voltage, source PLL synthesizer and level controller (ALC) tests. If the E5053 test fails, perform the E5053 test in Service Function Menu to narrow down failure possibilities.

The following procedure can be used to restart the E5053 self test as required.

- Press **System** key.
- Click **Service Menu** and, then, click **Service Function - Service Functions** in the softkeys.
- Password dialog box opens. Enter the password **kid** in the Password box and then click "OK" button.
- Click **Service Functions - E5053**. Then click **E5053 Test**.
- Click **Execute Test** to restart the test. Wait until the power-on test ends.
- The test results can be displayed with result softkeys (**A4 Result** through **A12 Result**) as shown in Figure 4-4. The A4 through A12 mean the analog sections (boards) of the E5053A.

NOTE

When "hex 0" status is displayed in the results softkey, the corresponding analog section passes. When a different status is displayed in the results softkey, the corresponding analog section fails.

Figure 4-4 E5053 Test softkey menu

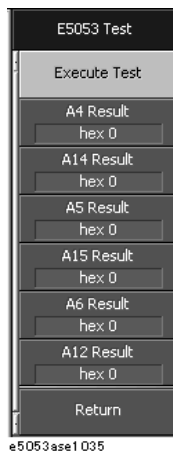

Contents of the power on test results

The E5053 test contains 6 test results shown in Figure 4-4. Each test result can display various operating characteristics of the analog measurement section. You can identify a failure section with the test results. When the E5053 Test is performed, “true” or “false” is indicated for each test item.

A4 Result

Figure 4-5 is an example of the A4 Result.

Figure 4-5

A4 Result example

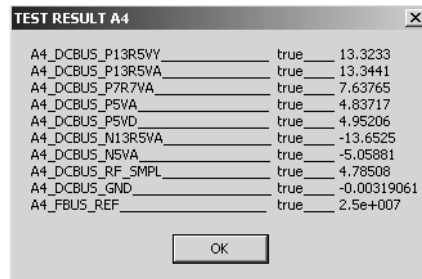

e5053ase1 036

A14 Result

Figure 4-6 is an example of the A14 Result.

Figure 4-6

A14 Result example

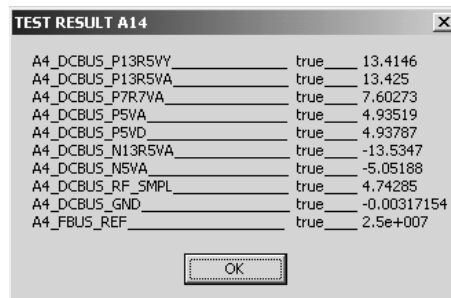

e5053ase1 037

A5 Result

Figure 4-7 is an example of the A5 Result.

Figure 4-7

A5 Result example

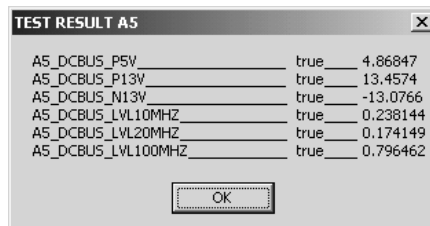

e5053ase1 038

A15 Result

Figure 4-8 is an example of the A15 Result.

Figure 4-8

A15 Result example

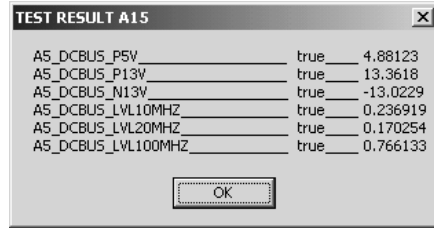

A6 Result

Figure 4-9 is an example of the A6 Result.

Figure 4-9

A6 Result example

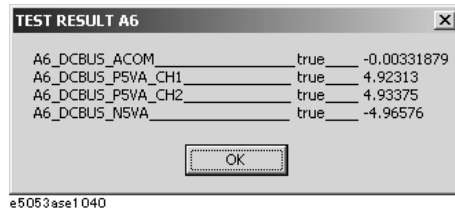

A12 Result

Figure 4-10 is an example of the A12 Result.

Figure 4-10

A12 Result example

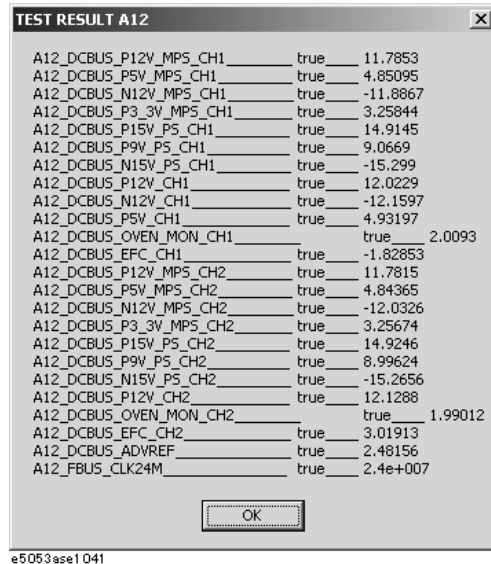

E5053 Test Failure Troubleshooting

Table 4-3 represents the contents of the test results and the relationships of failed tests to probable faulty board assemblies. If the instrument fails the E5053 test, replace the faulty board assembly as shown in Table 4-3.

Table 4-3 E5053 test failure troubleshooting information

Test result	Probable faulty board assembly							
	A4	A14	A5	A15	A6	A12	P.S (Ch1)	P.S (Ch2)
A4 Result	###					#	#	
A14 Result		###				#		#
A5 Result			###			#	#	
A15 Result				###		#		#
A6 Result					###	#	#	#
A12 Result						###	#	#

###: Most suspicious assembly

##: Suspicious assembly

#: Possible faulty assembly

Performance test failure troubleshooting

This section describes the adjustment and troubleshooting procedures used when the E5053A fails the performance tests. If the performance of the instrument is critical for the test limits and seems to be adjustable, perform first the adjustment(s) related to the failed test. When the test result is far from the tolerance of the test or the performance is not adjustable, isolate the faulty assembly in accordance with the "Performance tests failure troubleshooting procedure".

Recommended adjustment for performance test failure

Table 4-4 shows the recommended adjustments when the performance test fails. Select the adjustment program corresponding to the recommended adjustment and perform the adjustment.

When a test fails, check first whether the connections of the RF semi-rigid cables are tight or loose. Also check for possible disconnection (impairment) of the cables and connectors.

Table 4-4 Recommended adjustment for performance test failure

Test Num.	First failed test	Recommended adjustment							
		A4	A14	A5	A15	A6	A12	OCXO (Ch 1)	OCXO (Ch 2)
1	LOCAL Output Freq Acc Test (Channel 1)	√		√				√	
	LOCAL Output Freq Acc Test (Channel 2)		√		√				√
2	LOCAL Output Level Acc Test (Channel 1)	√							
	LOCAL Output Level Acc Test (Channel 2)		√						
3	Mixer Bias Output Current Acc Test (Channel 1)					√			
	Mixer Bias Output Current Acc Test (Channel 2)					√			
4	LOCAL Phase Noise Sensitivity Test (Chanel 1)	√	√	√	√	√			
	LOCAL Phase Noise sensitivity Test (Channel 2)	√	√	√	√	√			

Adjustment failure troubleshooting

Table 4-5 represents the relationships between the failed adjustment and probably faulty assembly. Note that this table lists some typical cases. There are possibilities that another assembly may be faulty.

Table 4-5 Adjustment failure troubleshooting information

Adj Num.	First failed adjustment	Probable faulty board assembly						
		OCXO (Ch1)	YIG (Ch1)	Mixer (Ch1)	A4	A5	A6	A12
1	VCXO Adjust (Channel 1)					###		#
2	OCXO Adjust (Channel 1)	###						##
3	Pretune Adjust (Channel 1)		##		###			#
4	Sampler RF Adjust (Channel 1)		##		###			#
5	Output level Adjust (Channel 1)		##		###			#
6	IF Path Adjust (Channel 1)						###	#
7	IF Gain Adjust (Channel 1)						###	#
8	Thru Path Adjust (Channel 1)						###	#
9	Mixer IF Adjust (Channel 1)			###	#		#	#
10	Mixer RF Adjust (Channel 1)			###	#		#	#
11	Level Monitor Adjust (Channel 1)						###	##
12	Current Source Adjust (Channel 1)						###	#

###: Most suspicious assembly

##: Suspicious assembly

#: Possible faulty assembly

Table 4-6 Adjustment failure troubleshooting information

Adj Num.	First failed adjustment	Probable faulty board assembly						
		OCXO (Ch2)	YIG (Ch2)	Mixer (Ch2)	A14	A15	A6	A12
1	VCXO Adjust (Channel 2)					###		#
2	OCXO Adjust (Channel 2)	###						##
3	Pretune Adjust (Channel 2)		##		###			#
4	Sampler RF Adjust (Channel 2)		##		###			#
5	Output level Adjust (Channel 2)		##		###			#
6	IF Path Adjust (Channel 2)						###	#
7	IF Gain Adjust (Channel 2)						###	#
8	Thru Path Adjust (Channel 2)						###	#
9	Mixer IF Adjust (Channel 2)			###	#		#	#
10	Mixer RF Adjust (Channel 2)			###	#		#	#
11	Level Monitor Adjust (Channel 2)						###	##
12	Current Source Adjust (Channel 2)						###	#

###: Most suspicious assembly

##: Suspicious assembly

#: Possible faulty assembly

Performance test failure troubleshooting

Table 4-7 represents the relationships between the failed test and probable faulty assembly. If the performance test failure cannot be removed by a proper adjustment, replace the assembly shown in this table.

Note that this table lists some typical cases. There are possibilities that another assembly may be faulty.

NOTE

When a test fails, check first whether the connections of the RF semi-rigid cables between the suspicious assembly and others are tight or loose. Also check for possible disconnection (impairment) of the cables and connectors.

Table 4-7 Performance test failure troubleshooting information

Test No.	First failed test	Probable faulty board assembly						
		OCXO (Ch1)	YIG (Ch1)	Mixer (Ch1)	A4	A5	A6	A12
1	LOCAL Output Freq Acc Test (Channel 1)	#			###	#		#
2	LOCAL Output Level Acc Test (Channel 1)		##		###	#		#
3	Mixer Bias Output Current Acc Test (Channel 1)						###	#
4	LOCAL Phase Noise Sensitivity Test (Channel 1/Channel 2)	#	##		###	#	#	#

###: Most suspicious assembly

##: Suspicious assembly

#: Possible faulty assembly

Table 4-8 Performance test failure troubleshooting information

Test No.	First failed test	Probable faulty board assembly						
		OCXO (Ch2)	YIG (Ch2)	Mixer (Ch2)	A14	A15	A6	A12
1	LOCAL Output Freq Acc Test (Channel 2)	#			###	#		#
2	LOCAL Output Level Acc Test (Channel 2)		##		###	#		#
3	Mixer Bias Output Current Acc Test (Channel 2)						###	#
4	LOCAL Phase Noise Sensitivity Test (Channel 1/Channel 2)	#	##		###	#	#	#

###: Most suspicious assembly

##: Suspicious assembly

#: Possible faulty assembly

Troubleshooting

Performance test failure troubleshooting

5 **Replaceable Parts**

This chapter contains information for ordering replacement parts for the E5053A.

Ordering Information

To order a part in the replaceable parts lists, quote the Agilent Technologies part number, indicate the quantity required, and address the order to the nearest Agilent Technologies Sales Office.

To order a part not listed in the replaceable parts lists, include the instrument model number, the description and function of the part, and the quantity of parts required. Address the order to the nearest Agilent Technologies Sales Office.

Direct Mail Order System

Within the USA, Agilent Technologies can supply parts through a direct mail order system. There are several advantages to this system:

- Direct ordering and shipping from the Agilent Technologies parts center in California, USA.
- No maximum or minimum on any mail order. (There is a minimum amount for parts ordered through a local Agilent Technologies Sales Office when the orders require billing and invoicing.)
- Prepaid transportation. (There is a small handling charge for each order.)
- No invoices.

In order for Agilent Technologies to provide these advantages, please send a check or money order with each order.

Mail order forms and specific ordering information are available through your local Agilent Technologies Sales Office. Addresses and telephone numbers are located in a separate document shipped with the manuals.

Exchange Assemblies







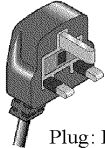

Under the rebuilt-exchange assembly program, certain factory-repaired and tested assemblies are available on a trade-in basis. These assemblies are offered at lower cost than a new assembly, but meet all factory specifications required of a new assembly.

The defective assembly must be returned for credit under the terms of the rebuilt-exchange assembly program. Any spare assembly stock desired should be ordered using the new assembly part number.

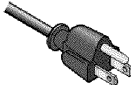
Replaceable Parts List

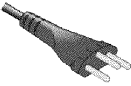
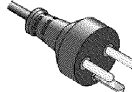
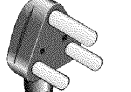
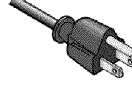
Power Cables and Plug Configurations

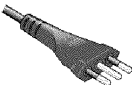
Figure 5-1 Power Cables and Plug Configurations

<p>OPTION 900</p>  <p>United Kingdom</p> <p>Plug: BS 1363/A, 250V, 10A Cable: 8120-1351, 8120-8705</p>	<p>OPTION 901</p>  <p>Australia/New Zealand</p> <p>Plug: AS 3112, 250V, 10A Cable: 8120-1369</p>
<p>OPTION 902</p>  <p>Continental Europe</p> <p>Plug: CEE 7 Standard Sheet VII, 250V, 10A Cable: 8120-1689</p>	<p>OPTION 903</p>  <p>U.S./Canada</p> <p>Plug: NEMA 5-15P, 125V, 10A Cable: 8120-1378</p>
<p>OPTION 904</p>  <p>U.S./Canada</p> <p>Plug: NEMA 6-15P, 250V, 6A Cable: 8120-0698</p>	<p>OPTION 906</p>  <p>Switzerland</p> <p>Plug: SEV Type 12, 250V, 10A Cable: 8120-2104</p>
<p>OPTION 912</p>  <p>Denmark</p> <p>Plug: SR 107-2-D, 250V, 10A Cable: 8120-2956</p>	<p>OPTION 917</p>  <p>India/Republic of S. Africa</p> <p>Plug: IEC 83-B1, 250V, 10A Cable: 8120-4211</p>
<p>OPTION 918</p>  <p>Japan</p> <p>Plug: JIS C 8303, 125V, 12A Cable: 8120-4753</p>	<p>OPTION 920</p>  <p>Argentina</p> <p>Plug: Argentine Resolution 63, Annex IV, 250V, 10A Cable: 8120-6870</p>
<p>OPTION 921</p>  <p>Chile</p> <p>Plug: CEI 23-16, 250V, 10A Cable: 8120-6978</p>	<p>OPTION 922</p>  <p>China</p> <p>Plug: GB 1002, 250V, 10A Cable: 8120-8376</p>
<p>NOTE: Each option number includes a 'family' of cords and connectors of various materials and plug body configurations (straight, 90° etc.).</p>	

power_e

Top View (Major Assemblies)

Figure 5-2

Top View (Major Assemblies)

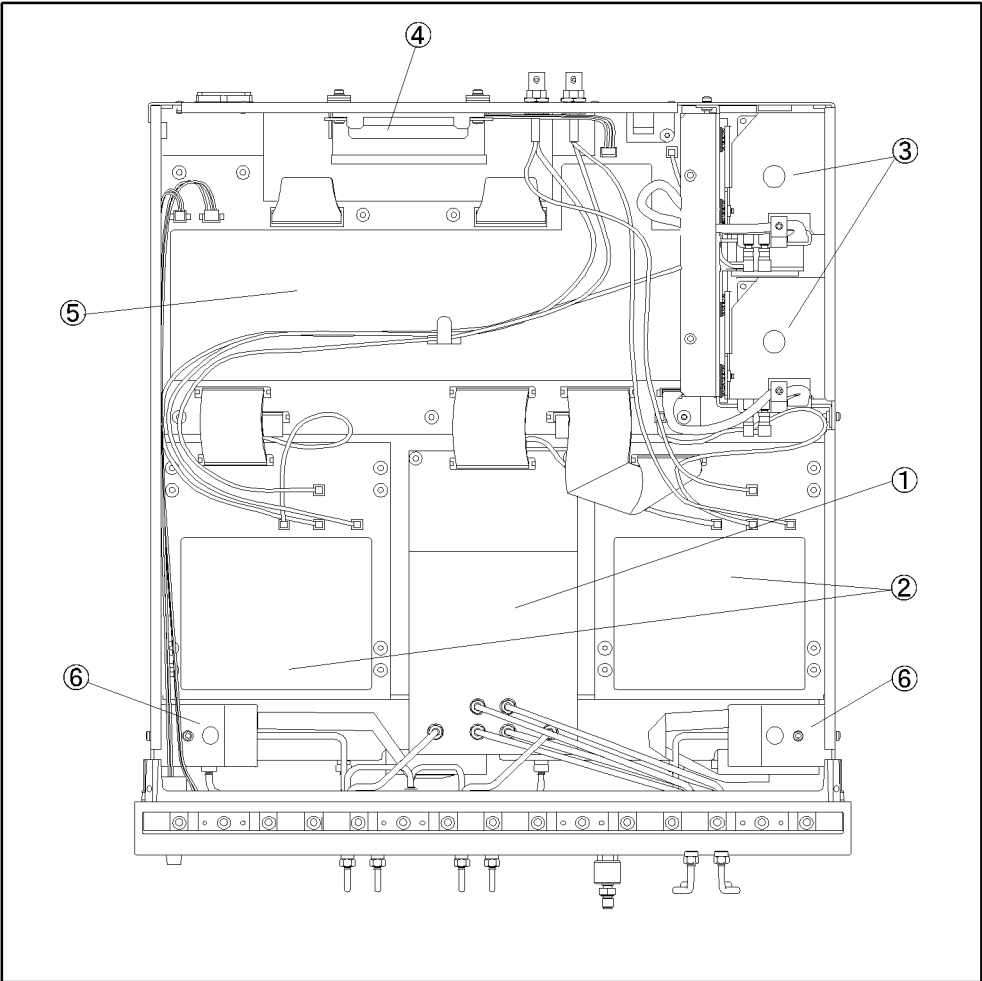

e5053ase1004

Table 5-1 Top View (Major Assemblies)

Ref. Desig.	Agilent Part Number	Qty.	Description
1	E5053-62006	1	A6 RECEIVER ASSEMBLY
2	E5053-62005	2	A5/A15 REFERENCE PLL ASSEMBLY
	E5053-69005	2	A5/A15 REFERENCE PLL ASSEMBLY (Exchange)
3	See Table 5-10	2	OCXO ASSEMBLY
4	See Table 5-14	1	FAN ASSEMBLY
5	E5053-62012	1	A12 PIS DIGIFUL I/F ASSEMBLY
6	See Table 5-13	2	YIG ASSEMBLY

Replaceable Parts
Replaceable Parts List

Top View (Cables)

Figure 5-3

Top View (Cables)

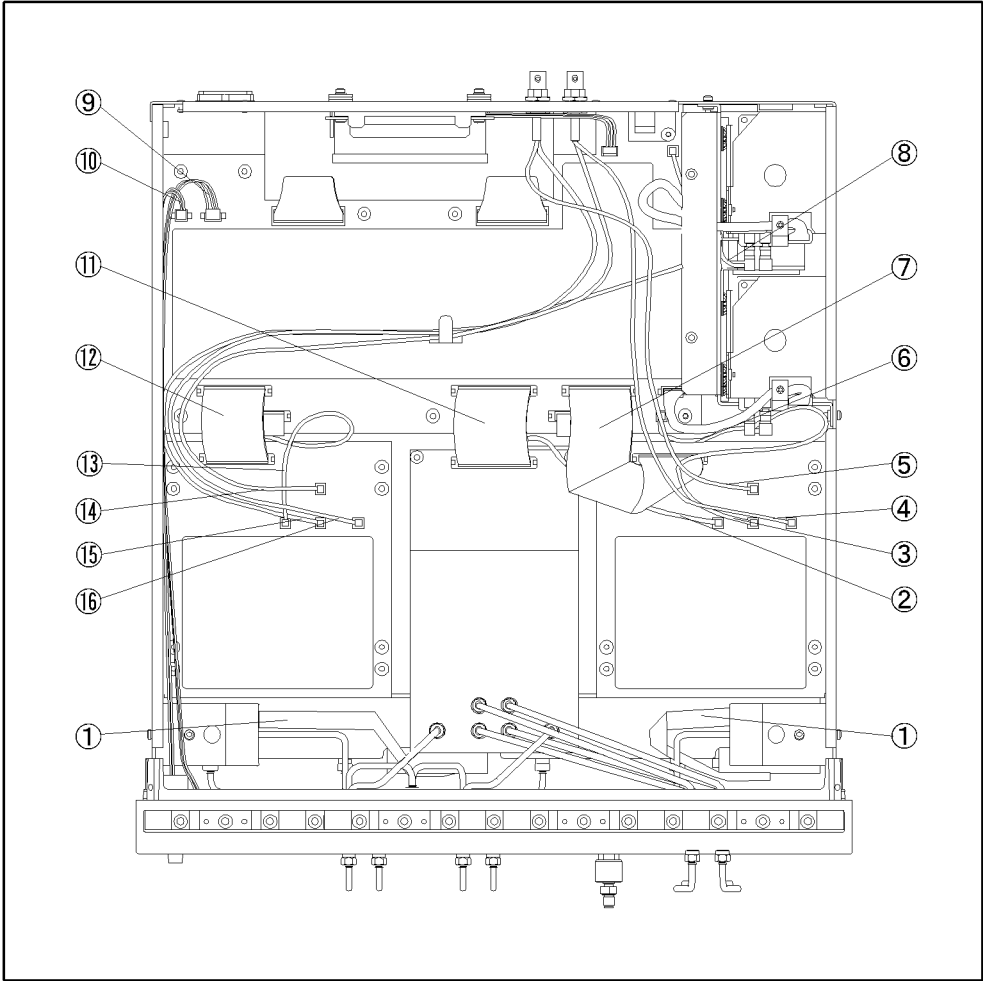

e5053ase1005

Table 5-2 Top View (Cables)

Ref. Desig.	Agilent Part Number	Qty.	Description
1	E5053-61644	2	FLAT CABLE ASSEMBLY
2	E5053-61639	1	RF CABLE ASSEMBLY
3	E5053-61631	1	RF CABLE ASSEMBLY
4	E5053-61635	1	RF CABLE ASSEMBLY
5	E5053-61637	1	RF CABLE ASSEMBLY
6	E5053-61633	1	RF CABLE ASSEMBLY
7	E5053-61645	1	FLAT CABLE ASSEMBLY
8	E5053-61634	1	RF CABLE ASSEMBLY
9	E5053-61653	1	WIRE CABLE ASSEMBLY
10	E5053-61901	1	SW WIRE ASSY
11	E5053-61643	1	FLAT CABLE ASSEMBLY
12	E5053-61646	1	FLAT CABLE ASSEMBLY
13	E5053-61640	1	RF CABLE ASSEMBLY
14	E5053-61638	1	RF CABLE ASSEMBLY
15	E5053-61632	1	RF CABLE ASSEMBLY
16	E5053-61636	1	RF CABLE ASSEMBLY

Top View (Miscellaneous Parts)

Figure 5-4

Top View (Miscellaneous Parts)

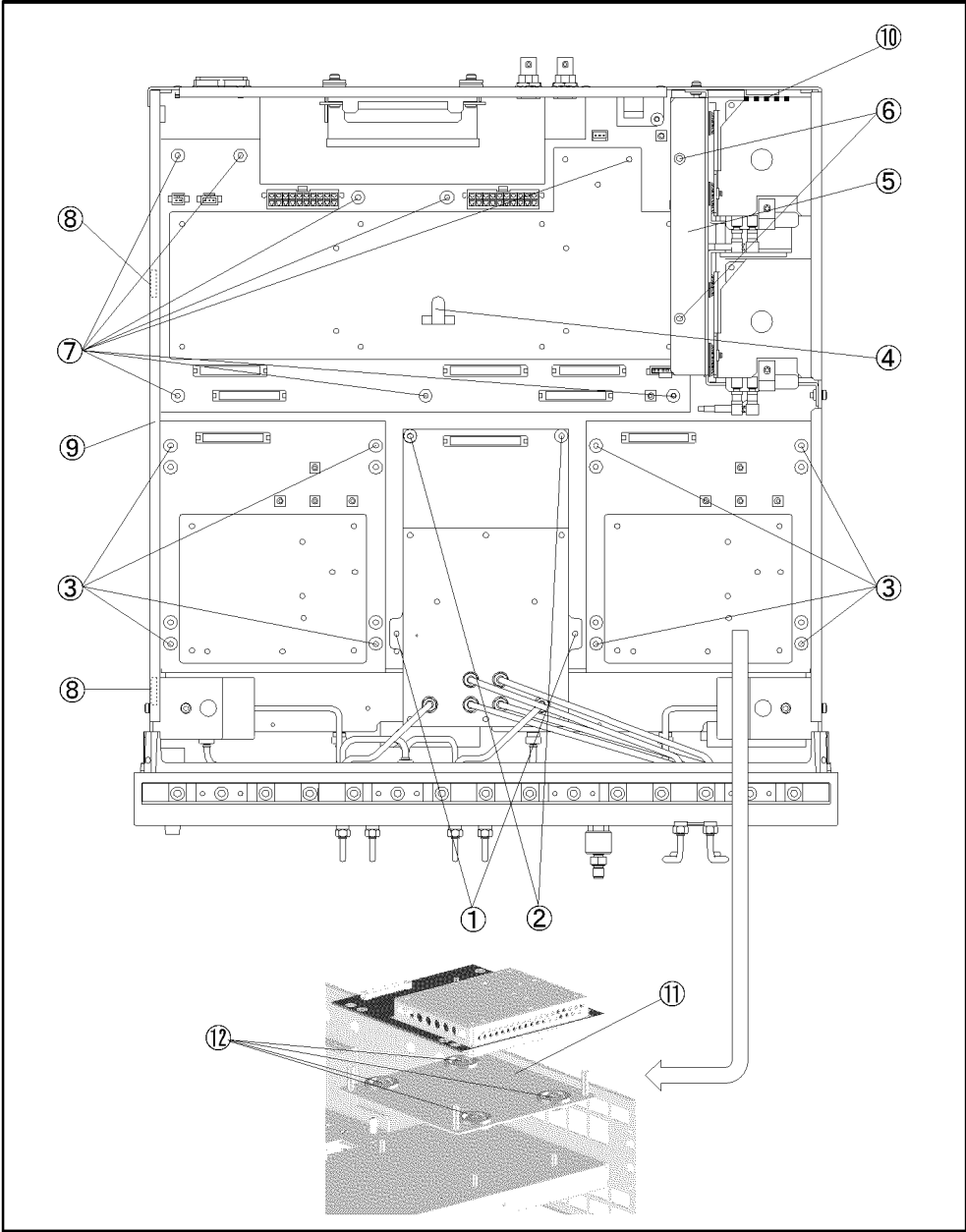

e5053ase1006

Table 5-3 Top View (Miscellaneous Parts)

Ref. Desig.	Agilent Part Number	Qty.	Description
1	0515-0666	2	SCREW-MACH M3.0 x L18 PN T10
2	0515-0372	2	SCREW-MACH M3.0 x L8 PN T10
3	0515-0372	8	SCREW-MACH M3.0 x L8 PN T10
4	1400-1334	1	CLAMP CABLE
5	E5053-01204	1	ANGLE
6	0515-2032	2	SCREW-MACH M3.0 x L8 FL T10
7	0515-0372	8	SCREW-MACH M3.0 x L8 FL T10
8	1400-1334	2	CLAMP CABLE
9	E5053-60001	1	CHASSIS ASSY
10	4324-0605	1	GEL TYPE INSL
11	E5053-00653	2	PLATE
12	1520-0205	8	GROMMET
	0515-0372	8	SCREW-MACH M3.0 x L8 PN T10
	3050-0105	8	WASHER

Bottom View (Major Assembly/Cables)

Figure 5-5

Bottom View (Major Assembly / Cables)

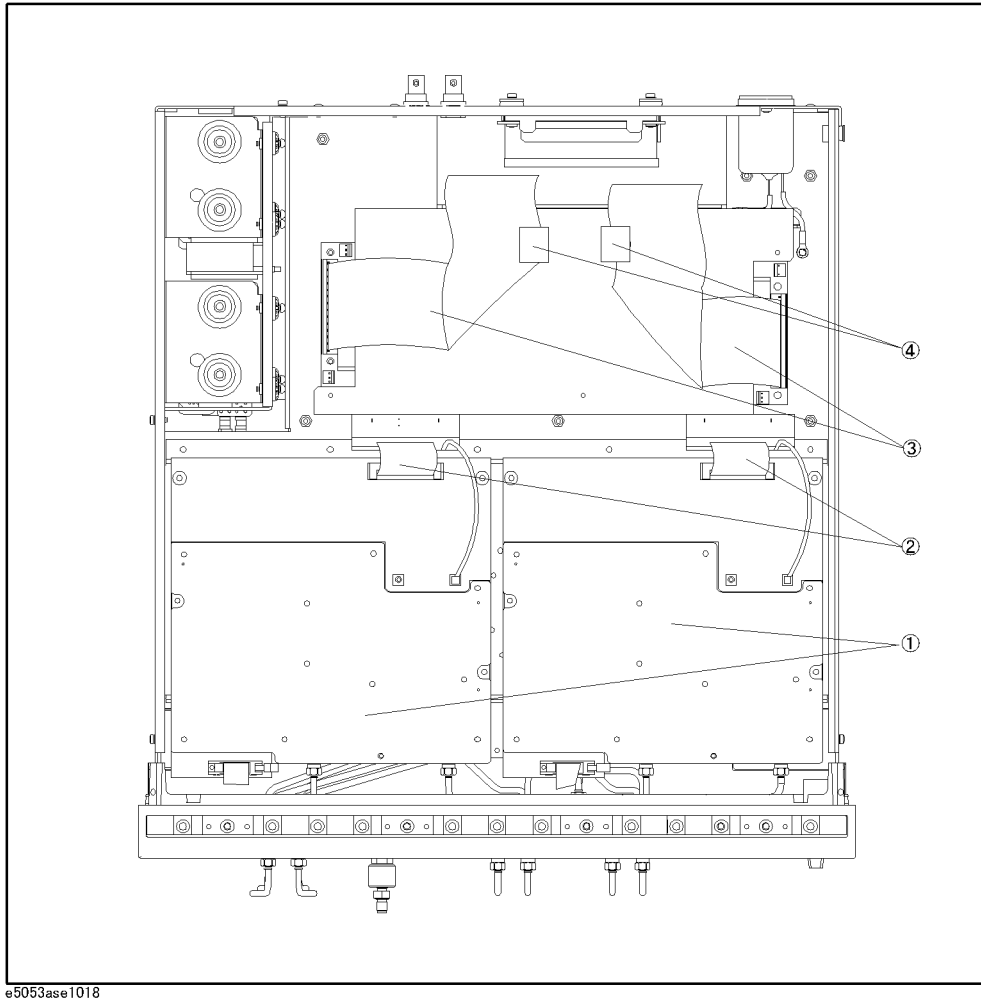

e5053ase1018

Table 5-4 Bottom View (Major Assembly / Cables)

Ref. Desig.	Agilent Part Number	Qty.	Description
1	E5053-62004	2	A4/A14 YIG PLL ASSEMBLY
	E5053-69004	2	A4/A14 YIG PLL ASSEMBLY (Exchange)
2	E5053-61646	2	FLAT CABLE
3	E5053-61652	2	WIRE ASSY
4	1400-0661	2	CLAMP CABLE

Bottom View (Miscellaneous Parts)

Figure 5-6

Bottom View (Miscellaneous Parts)

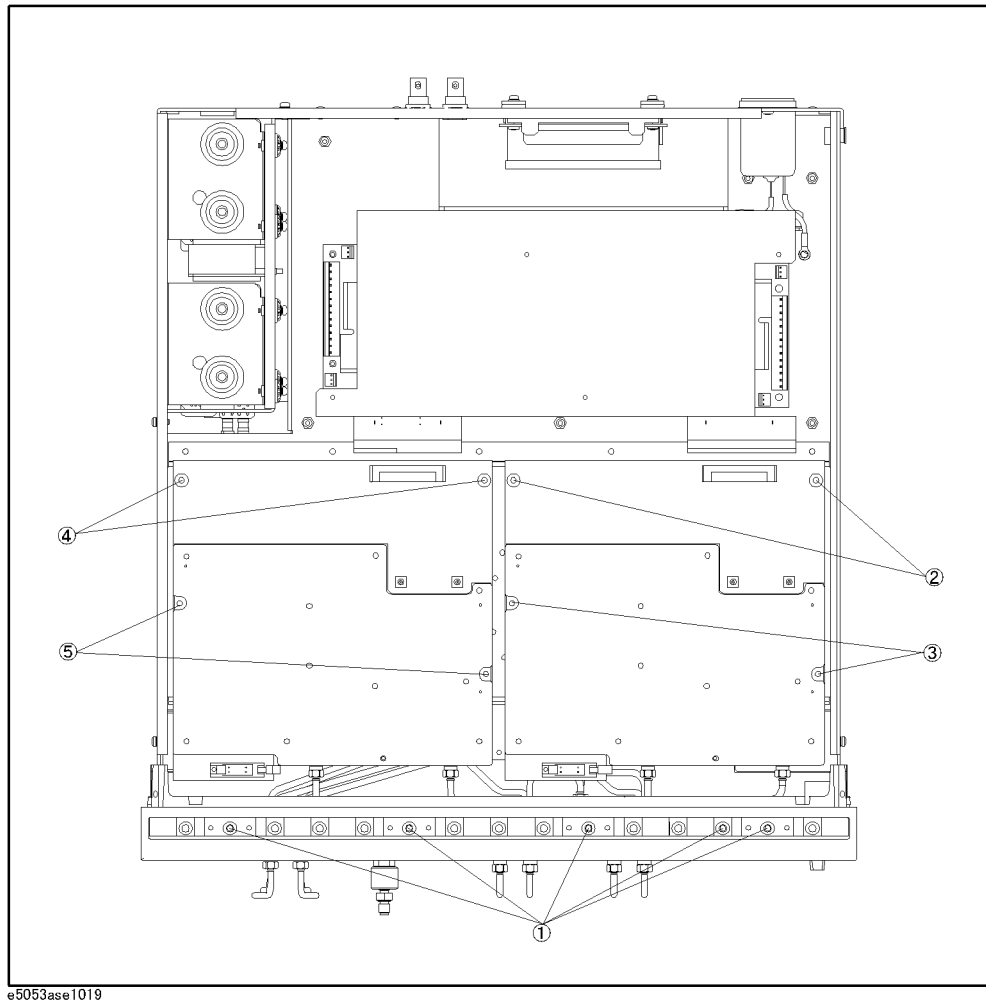

e5053ase1019

Table 5-5 Bottom View (Miscellaneous Parts)

Ref. Desig.	Agilent Part Number	Qty.	Description
1	0515-1382	5	SCREW-MACH M3.5 x 6 FL T15
2	0515-0372	2	SCREW-MACH M3.0 x 8 PN T10
3	0515-0666	2	SCREW-MACH M3.0 x 8 PN T10
4	0515-0372	2	SCREW-MACH M3.0 x 8 PN T10
5	0515-0666	2	SCREW-MACH M3.0 x 8 PN T10

Top/Front View (Cables)

Figure 5-7

Front View (Cables)

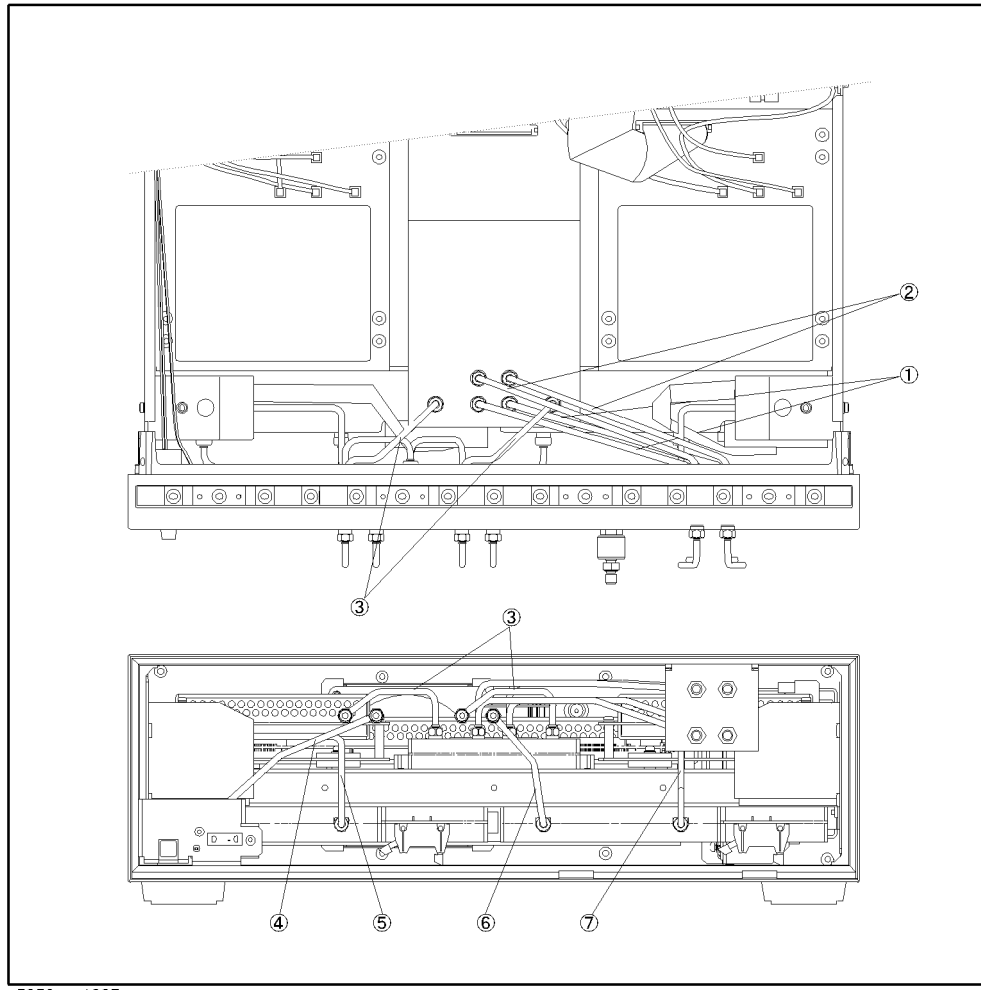

e5053ase1007

Table 5-6 Top/Front View (Cables)

Ref. Desig.	Agilent Part Number	Qty.	Description
1	E5053-61612	2	RF CABLE SR
2	E5053-61614	2	RF CABLE SR
3	E5053-61609	2	RF CABLE SR
4	E5053-61604	1	RF CABLE SR
5	E5053-61602	1	RF CABLE SR
6	E5053-61603	1	RF CABLE SR
7	E5053-61601	1	RF CABLE SR

Front View (Miscellaneous Parts)

Figure 5-8

Front View (Miscellaneous Parts)

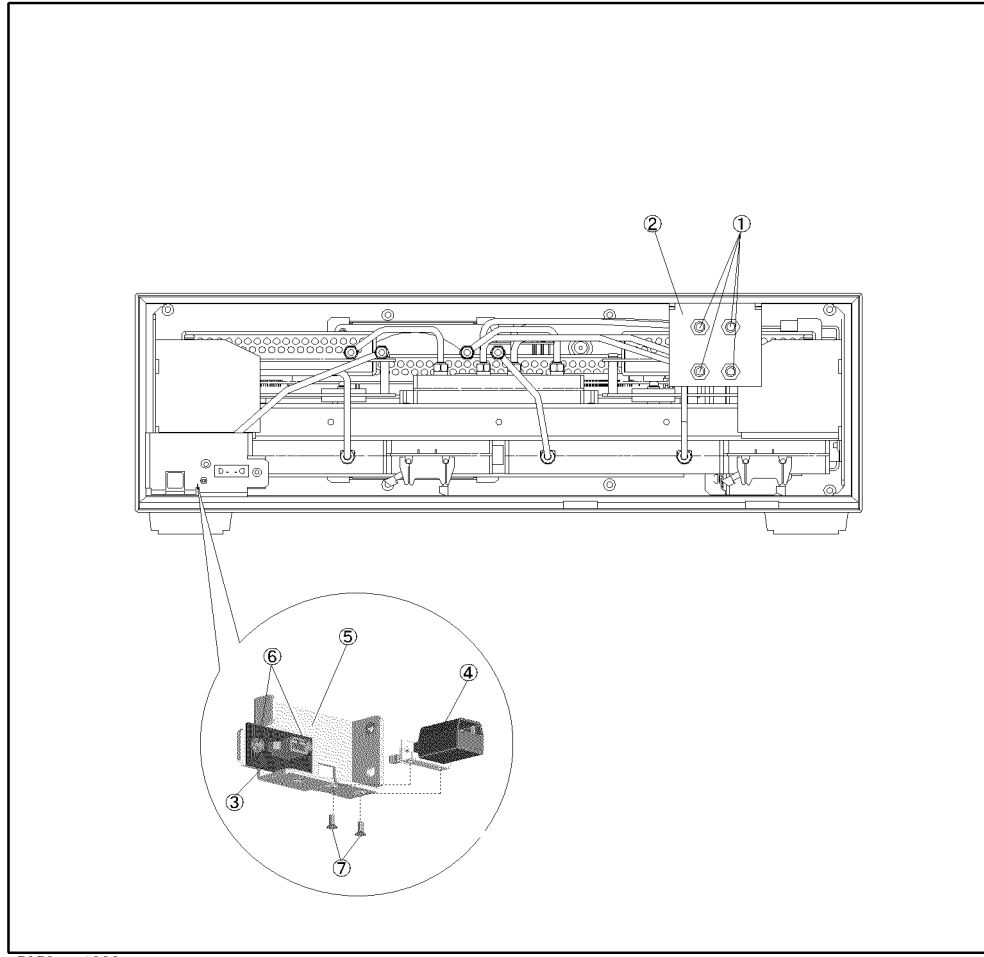

e5053ase1008

Table 5-7

Front View (Miscellaneous Parts)

Ref. Desig.	Agilent Part Number	Qty.	Description
1	1250-1251	4	ADAPTER SMA(F)-SMA(F)
2	E5053-01203	1	ANGLE
3	E5053-66511	1	LED BOARD
4	E5053-61901	1	SW WIRE ASSY
5	E5053-01202	1	ANGLE
6	0515-0430	2	SCREW-MACH M3.0 x L6 PN T10
7	0515-2028	2	SCREW-MACH M2.5 x L6 FL T8

Replaceable Parts
Replaceable Parts List

Rear View

Figure 5-9

Rear View

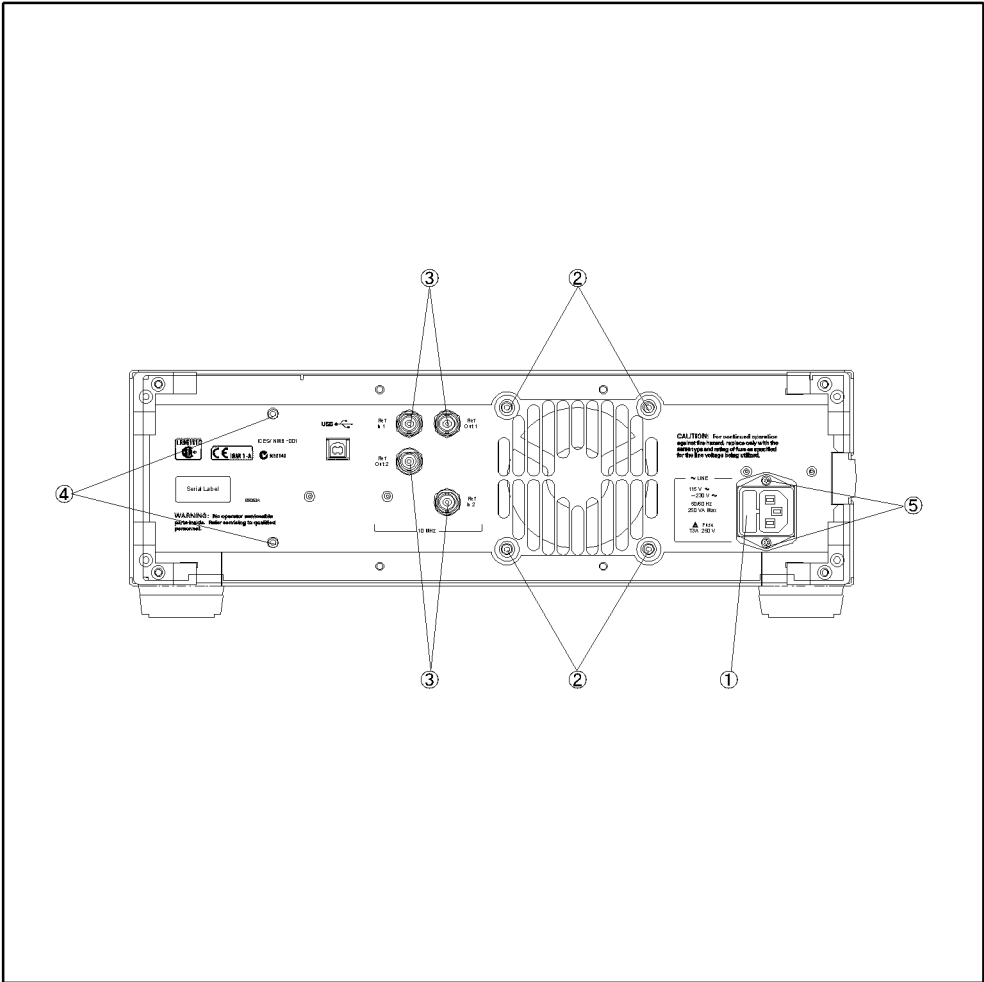

e5053ase1010

Table 5-8 Rear View

Ref. Desig.	Agilent Part Number	Qty.	Description
1	2110-1017	1	FUSE 3A 250V
2	0515-0666	4	SCREW-MACH M3.0 x L18 PN T10
	E5070-24011	4	WAHSER
3	1250-0252	4	BNC CONN
	2190-0102	4	WAHSER
	2950-0035	4	NUT
4	0515-0372	2	SCREW-MACH M3.0 x L8 PN T10
5	0515-2032	2	SCREW-MACH M3.0 x L8 FL T10

Cover Assembly

Figure 5-10

Cover Assembly

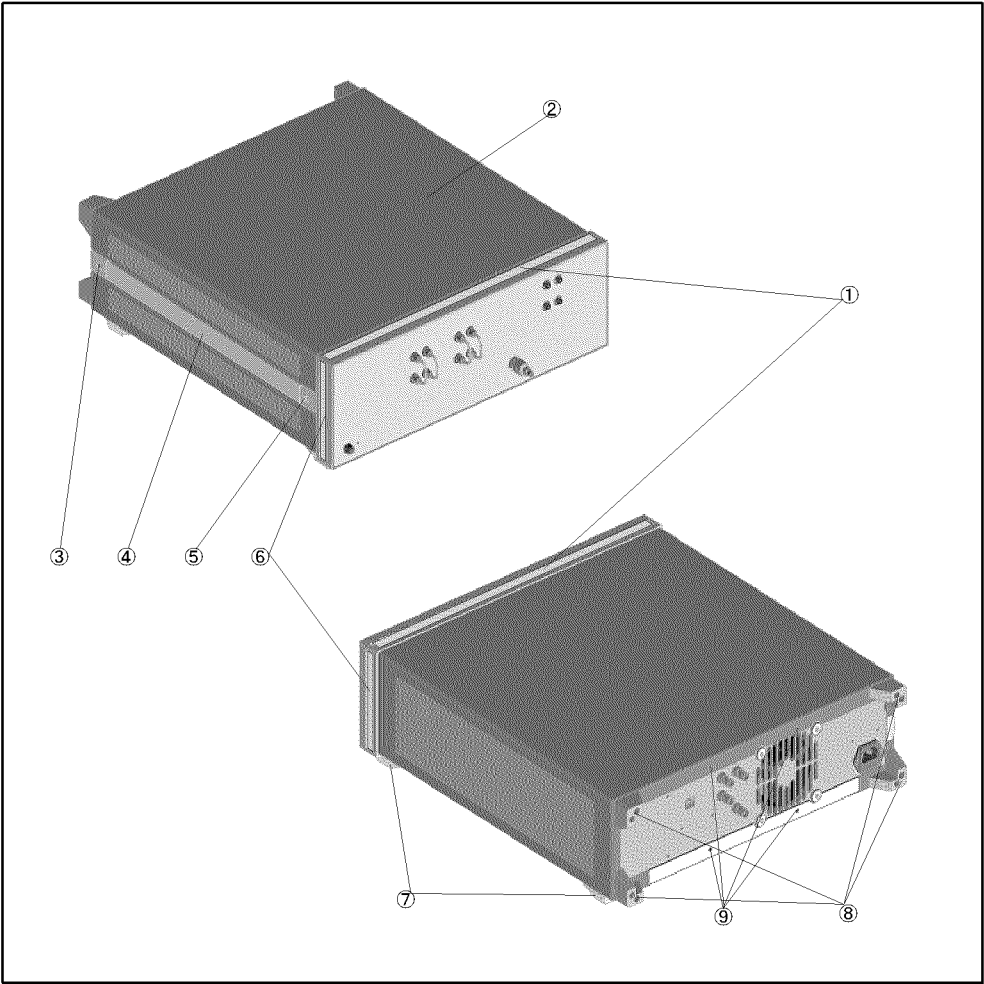

e5053ase1011

Table 5-9 Cover Assembly

Ref. Desig.	Agilent Part Number	Qty.	Description
1	5041-9176	1	TRIM STRIP
2	E5053-60002	1	COVER ASSEMBLY
3	5041-9187	1	STRAP HANDLE REAR
	0515-2049	1	SCREW-MACH M5.0 x L16 FL T20
4	08720-00081	1	STRAP HANDLE
5	5041-9186	1	STRAP HANDLE FRT
	0515-2049	1	SCREW-MACH M5.0 x L16 FL T20
6	5041-9171	2	SIDE TRIM STRIP
7	5041-9167	4	FOOT FL
	5021-2840	4	KEY LOCK
	1460-1345	2	WIREFORM
8	E5100-40002	4	STANDOFF
	0515-1402	4	SCREW-MACH M3.5 x L8 PN T15
9	0515-1402	4	SCREW-MACH M3.5 x L8 PN T15

OCXO Assembly

Figure 5-11

OCXO Assembly

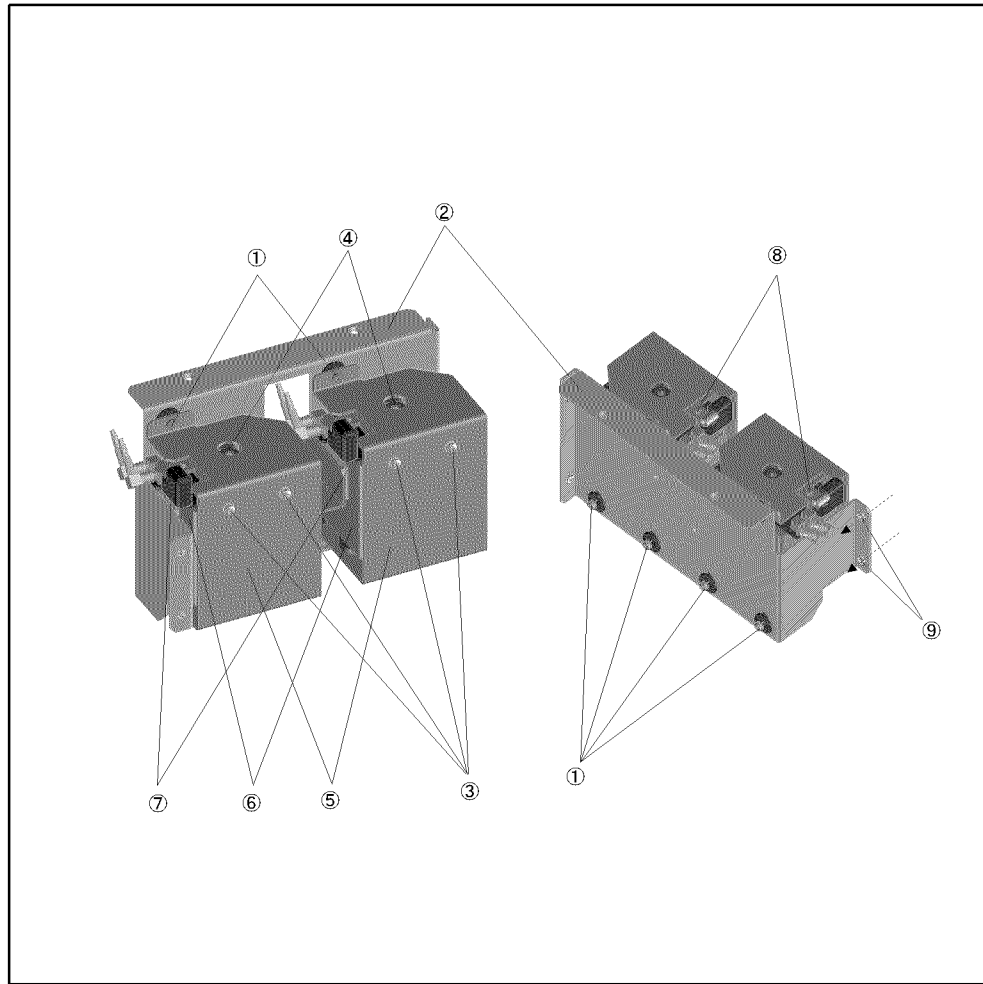

e5053ase1016

Table 5-10 **OCXO Assembly**

Ref. Desig.	Agilent Part Number	Qty.	Description
1	0400-0356	6	GROMMET
	0380-1402	6	SPACER
	0515-0665	6	SCREW-MACH M3.0 x L14 PN T10
	3050-1628	6	WASHER
2	E5053-01204	1	ANGLE
3	0515-0372	4	SCREW-MACH M3.0 x L8 PN T10
4	2200-0103	6	SCREW-MACH 4-40 0.25-IN-LG PN POZI
	3050-0105	6	WASHER
	1520-0205	6	GROMMET
5	E8251-00040	2	C BRACKET
6	1813-1899	2	OCXO
7	4324-0605	4	GEL TYPE INSL
8	E8251-00041	2	L BRACKET
9	0515-0372	4	SCREW-MACH M3.0 x L8 PN T10

Front Panel Assembly

Figure 5-12 Front Panel Assembly

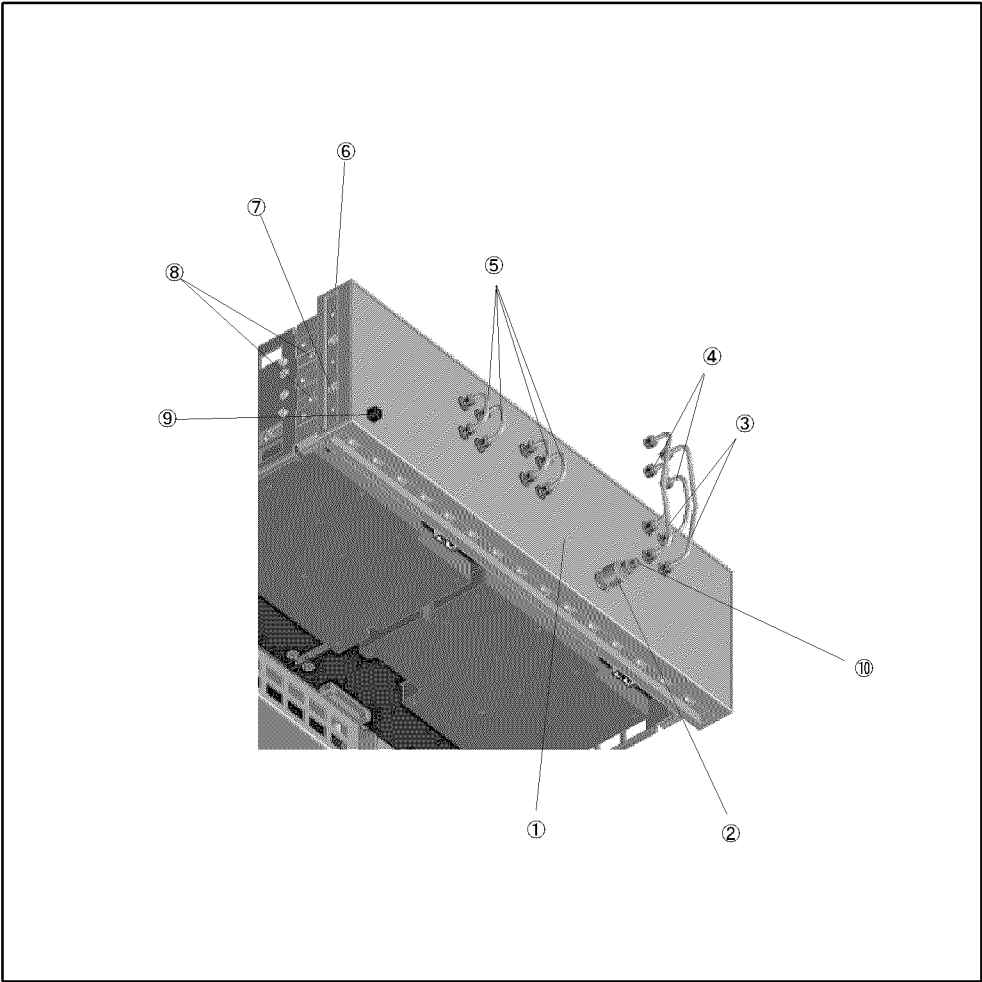

e5053ase1017

Table 5-11 Front Panel Assembly

Ref. Desig.	Agilent Part Number	Qty.	Description
1	E5053-00201	1	PANEL FRONT
	04191-08000	1	SPRING
2	08673-60040	1	CONNECTOR ASSEMBLY-OUTPUT
	2190-0016	1	WASHER
	2950-0001	1	NUT
3	E5053-61621	2	RF CABLE SR
4	E5053-61622	2	RF CABLE SR
5	E5052-61611	4	SR CABLE ASSY
6	5022-1188	1	FR FR FULL MDL
	8160-0641	1	RFI BRAID STRIP
7	0515-1382	1	SCREW-MACH M3.5 x L6 FL T15
8	0515-2113	4	SCREW-MACH M4.0 x L8 PN T20
9	0371-3953	1	KEY CAP
10	5061-5311	1	CONNECTOR ASSY 3.5MM FEM-FEM

Front Panel Rear Assembly

Figure 5-13

Front Panel Rear Assembly

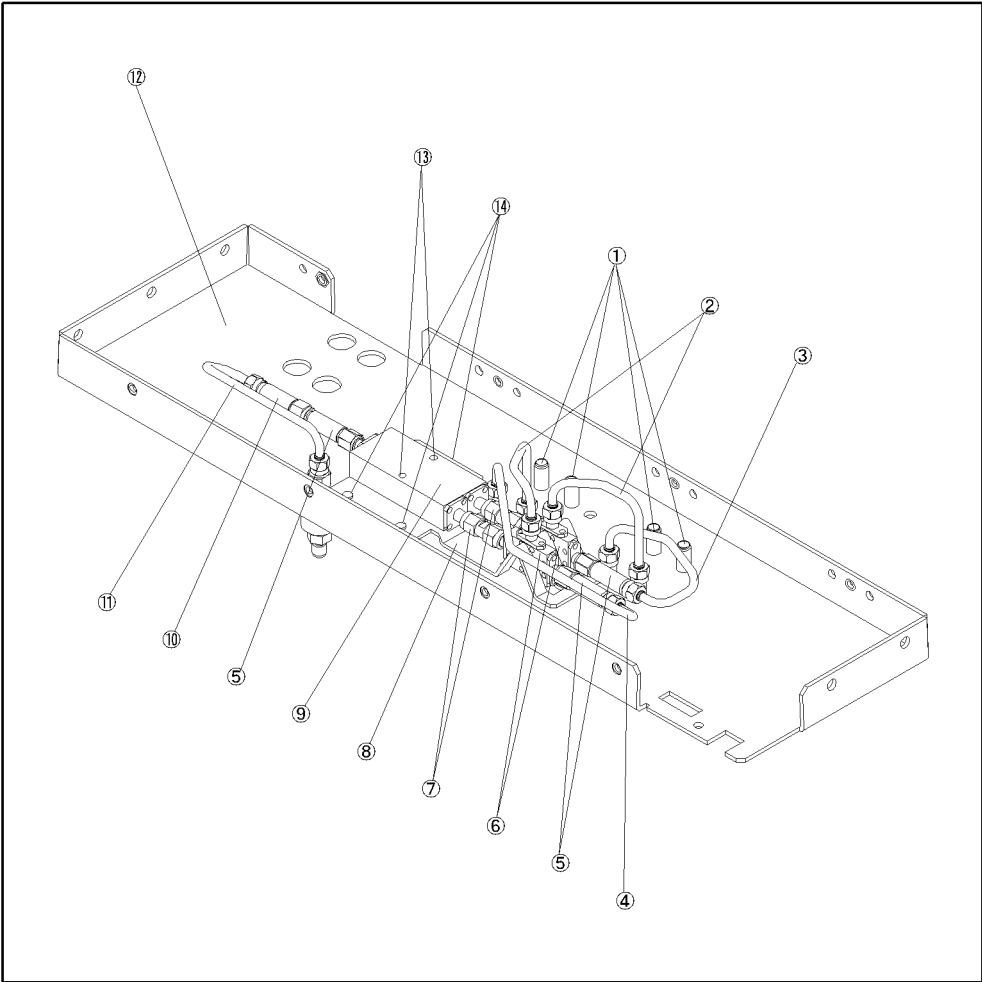

e5053.ase1033

Table 5-12 Front Panel Rear Assembly

Ref. Desig.	Agilent Part Number	Qty.	Description
1	1250-1251	8	ADAPTER SMA(F)-SMA(F)
2	E5053-61607	2	RF CABLE SR
3	E5053-61606	1	RF CABLE SR
4	E5053-61605	1	RF CABLE SR
5	08493-60013	3	3dB ATT
6	0955-1487	2	MIXER
7	1250-1788	2	ADAPTER SMA(M)-SMA(M)
8	E5053-01201	2	ANGLE
9	0955-1427	1	POWER DIVIDER
10	11742-60001	1	BLOCKING CAPACITOR
11	E5053-61613	1	RF CABLE SR
12	E5053-00202	1	PANEL SUB
13	0515-1410	2	SCREW-MACH M3.0 x L20 PN T10
14	0515-0372	3	SCREW-MACH M3.0 x L8 PN T10

YIG Assembly

Figure 5-14

YIG Assembly

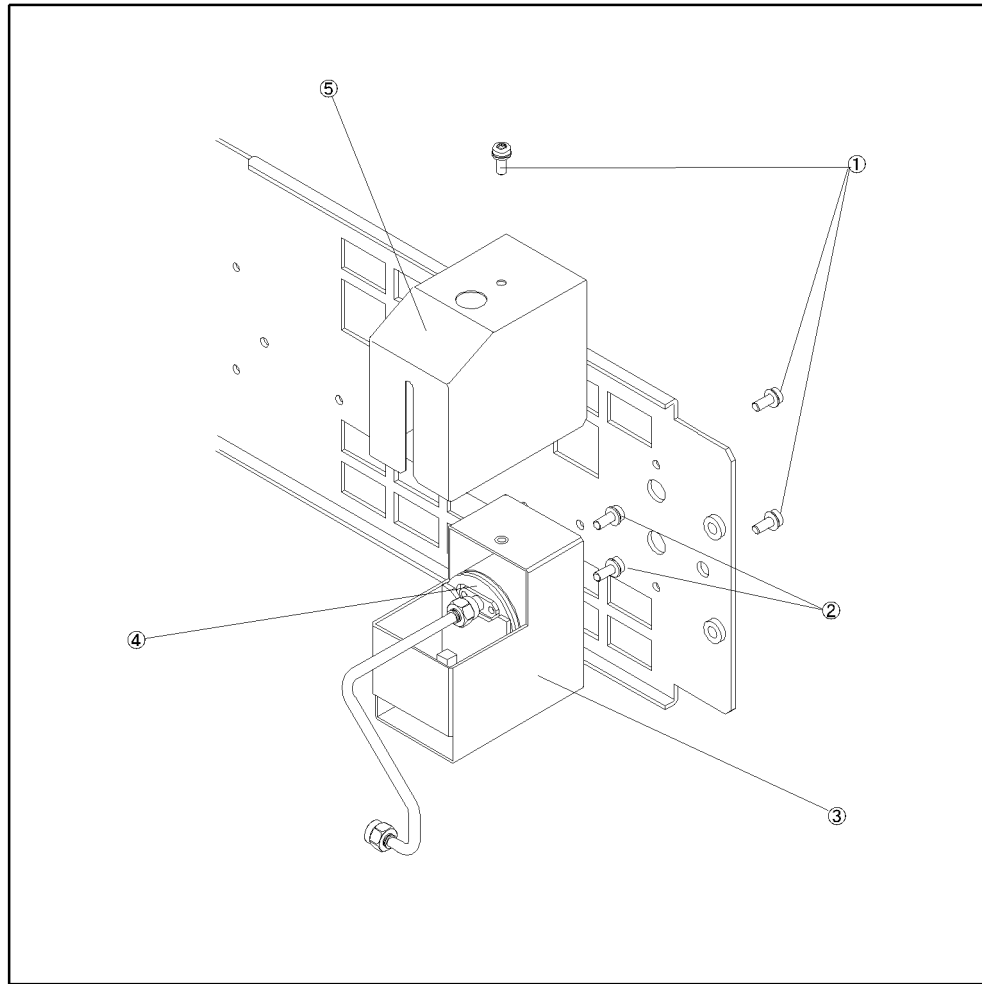

e5053ase1020

Table 5-13 YIG Assembly

Ref. Desig.	Agilent Part Number	Qty.	Description
1	0515-0372	3	SCREW-MACH M3.0 x L8 PN T10
2	0515-0430	2	SCREW-MACH M3.0 x L6 PN T10
3	E5053-00643	1	CASE SHIELD
4	5087-7715	1	OSC YIG
5	E5053-00644	1	CASE SHIELD

Fan Assembly

Figure 5-15

Fan Assembly

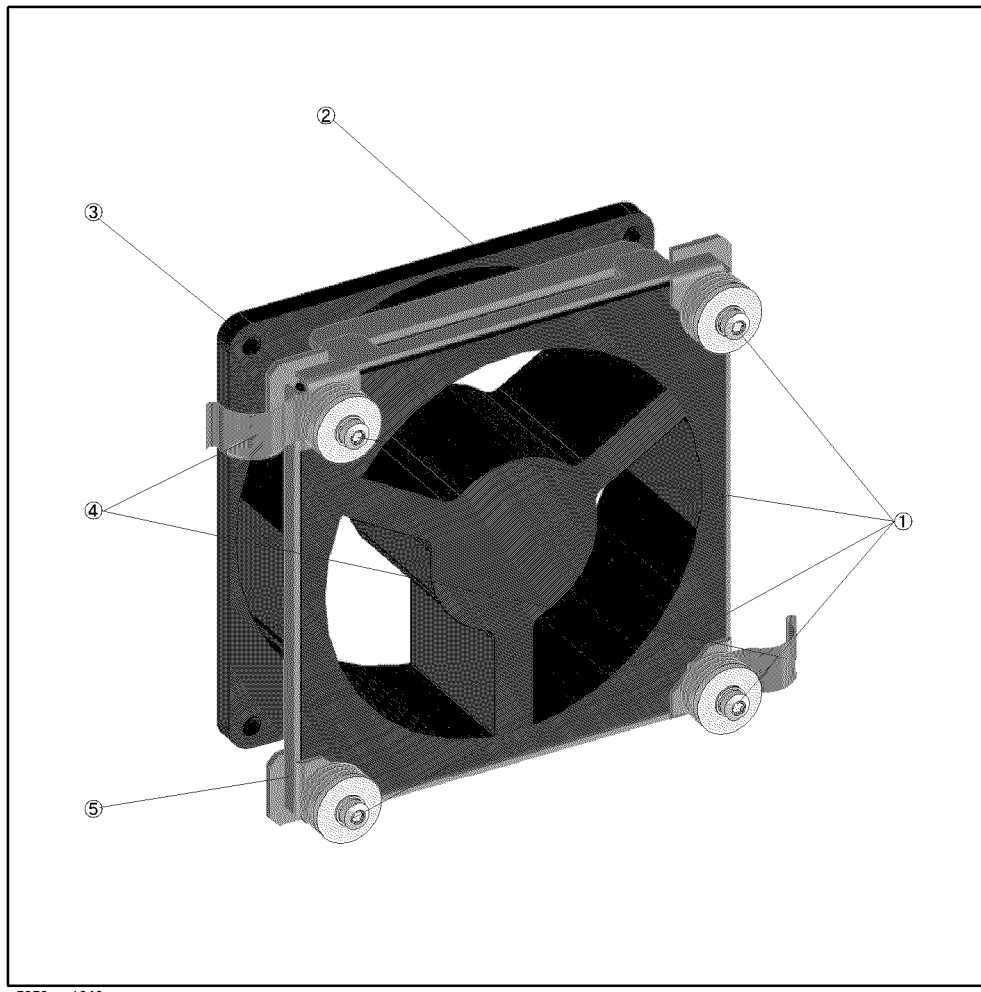

e5053ase1042

Table 5-14

Fan Assembly

Ref. Desig.	Agilent Part Number	Qty.	Description
1	0515-0666	4	SCREW-MACH M3.0 x L18 PN T10
	E5070-24011	4	WAHSER
	1410-1580	4	GEL BUSH
2	E5070-61005	1	FAN
3	E5053-00601	1	PLATE FAN MOUNT
4	8160-0441	2	RFI STRIP FINGER
5	E5053-00603	1	PLATE FAN SPACER

PS Wire Assembly

Figure 5-16

PS Wire Assembly

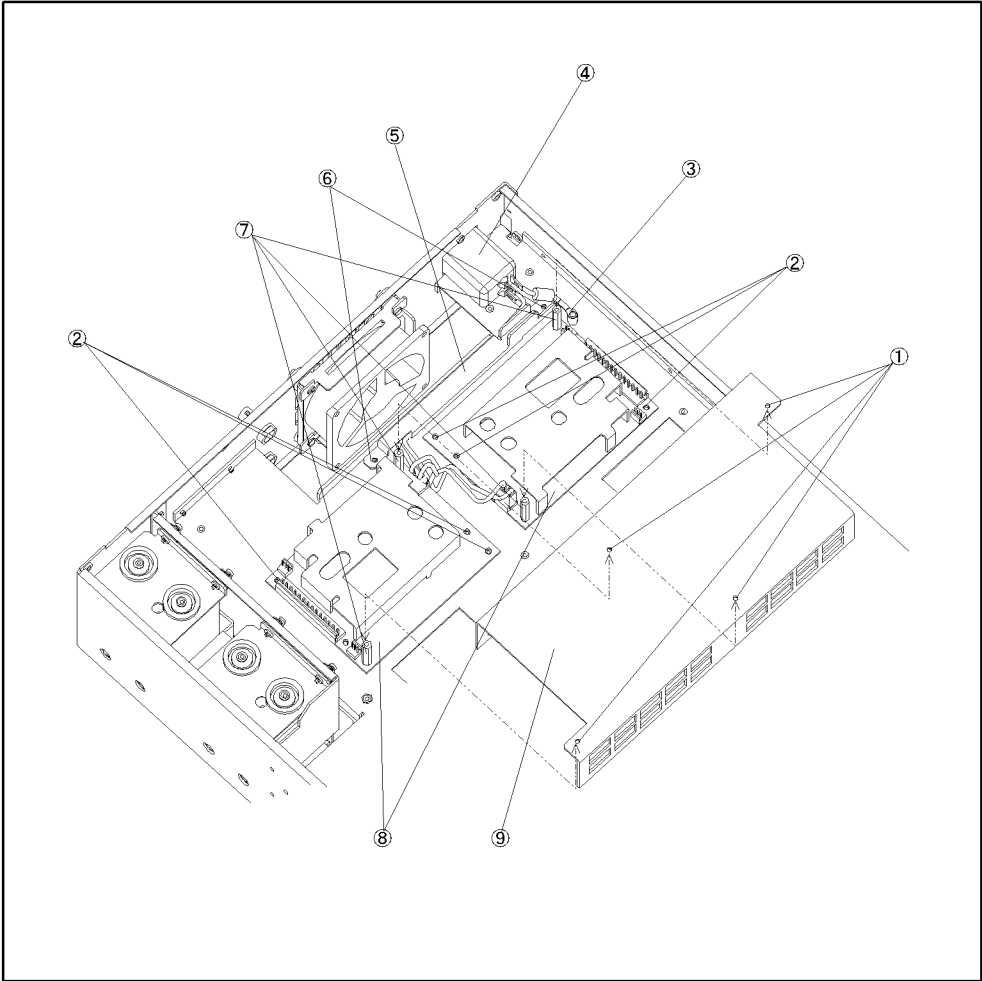

e5053ase1021

Table 5-15 PS Wire Assembly

Ref. Desig.	Agilent Part Number	Qty.	Description
1	0515-0372	4	SCREW-MACH M3.0 x L8 PN T10
2	0515-0372	8	SCREW-MACH M3.0 x L8 PN T10
3	0515-0380	1	SCREW-MACH M4.0 x L10 PN T20
4	E5053-61651	1	WIRE ASSY
5	E5053-04002	1	COVER
6	0515-0372	2	SCREW-MACH M3.0 x L8 PN T10
7	0380-4985	4	STANDOFF
8	E4980-60103	2	PWR SPLY
9	E5053-04001	1	COVER

Other Parts

Table 5-16 **Other Parts**

Agilent Part Number	Qty.	Description
E5053-900x0 ^{*1}	1	USER'S GUIDE
E5053-901x0 ^{*1}	1	SERVICE GUIDE
E5053-9050x ^{*1}	1	CD-ROM (DOCUMENTATION)

*1. The number indicated by "x" in the part number of each manual, or CD-ROM, 0 for the first edition, is incremented by 1 each time a revision is made. The latest edition comes with the product.

6 Replacement Procedure

This chapter provides procedure for removing and replacing the major assemblies in the E5053A.

Replacing an Assembly

The following steps show the sequence for replacing an assembly in the E5053A.

1. Identify the faulty group. Refer to Chapter 4, “Troubleshooting.”
2. Order a replacement assembly. Refer to Chapter 5, “Replaceable Parts.”
3. Replace the faulty assembly and determine what adjustments are necessary. Refer to This chapter and Chapter 7, “Post-Repair Procedures.”
4. Perform the necessary adjustments. Refer to Chapter 3, “Adjustment.”
5. Perform the necessary performance tests. Refer to Chapter 2, “Performance Tests.”

WARNING

These servicing instructions are for use by qualified personnel only. To avoid electrical shock, do not perform any servicing unless you are qualified to do so.

WARNING

The opening of covers or removal of parts is likely to expose dangerous voltages. Disconnect the instrument from its power supply.

CAUTION

Many of the assemblies in this instrument are very susceptible to damage from ESD(electrostatic discharge). Perform the following procedures only at a static-safe workstation and wear a grounding strap.

Required Tools

The following tools are required for repair of E5053A.

Table 6-1 Required Tools

Assembly	TORX screwdriver				flat edge screwdriver	pozi driver	open wrench				open torque wrench
	T8	T10	T15	T20			1/2 in.	3/8 in.	6.5 mm	5.5 mm	
Outer Cover		√	√	√							
Front Assembly		√	√	√	√						√
SW Wire Assembly	√	√	√	√	√						
RF IN connector		√	√	√	√		√				
Mixer		√	√	√	√				√		√
Power Divider		√	√	√	√			√		√	√
SMA connector		√	√	√	√			√			
Panel Front					√						√
A4/A14 YIG PLL		√	√	√		√					
A5/A15 REF PLL		√	√	√							
A6 Receiver		√	√	√							
A12 PIS DIGIFUL I/F		√	√	√							
OCCO		√	√	√		√					
YTO		√	√	√							√
Power Supply		√	√	√					√		
Inlet		√	√	√							
Fan		√	√	√							

Outer Cover Removal

Tools Required

- TORX screwdriver, T10, T15 and T20

Removal Procedure

Refer to Figure 6-1 for this procedure.

- Step 1.** Disconnect the power cable from the E5053A.
- Step 2.** Remove the four TORX T15 screws (item 1) fastening the four rear feet
- Step 3.** Remove the four TORX T15 screws (item 2) fastening the cover.
- Step 4.** Remove the two TORX T20 screws (item 3,4) fastening the side strap handles.
- Step 5.** Remove the four bottom feet (item 5).
- Step 6.** Slide the outer cover and remove it carefully.

Replacement Procedure

- Step 1.** Reverse the order of the removal procedure.

Figure 6-1 Outer Cover Removal

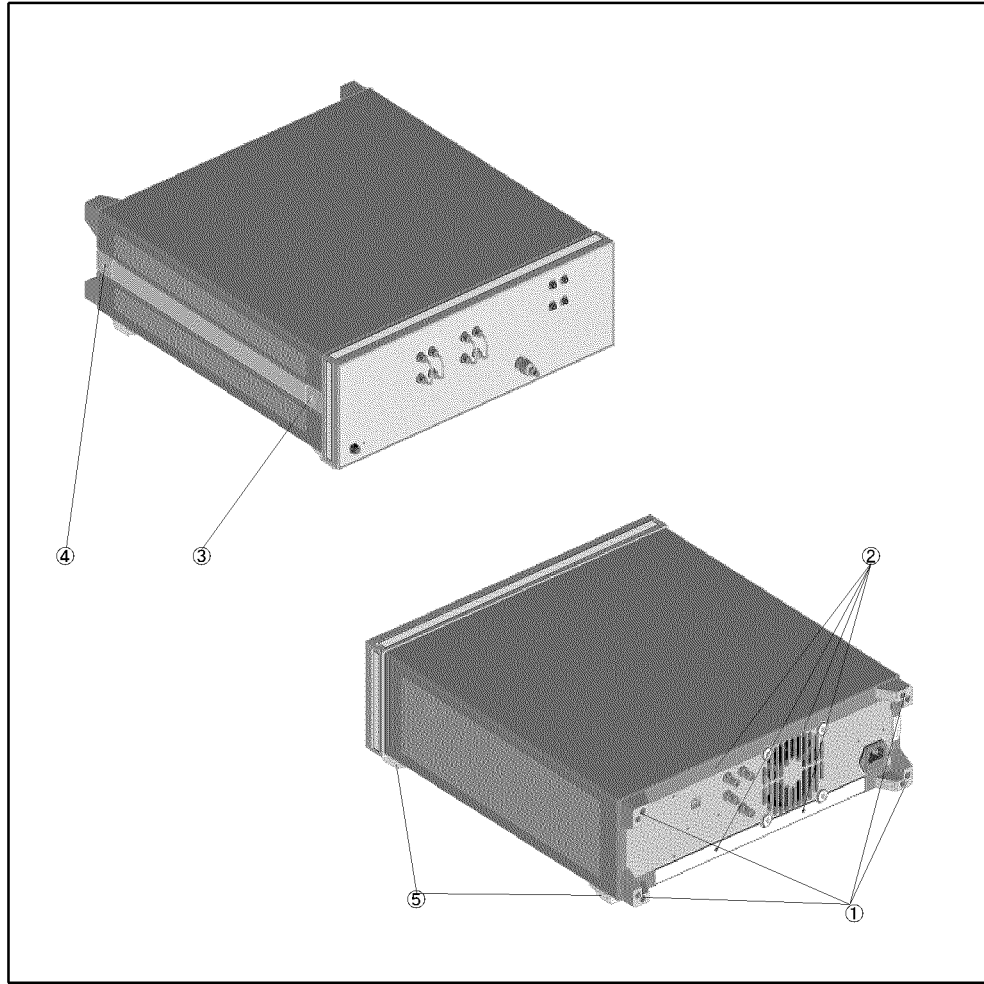

e5053ase1024

Front Assembly Removal

Tools required

- TORX screwdriver T10, T15 and T20
- Flat edge screwdriver
- Open-end torque wrench, 5/16 inch (set to 10 in-lb) (for reconnecting SMA connector)

Removal Procedure

Refer to Figure 6-2 for this procedure.

Step 1. Remove the outer cover as described in “Outer Cover Removal” on page 80.

Step 2. Disconnect the four semi-rigid cables (item 1) from the front panel.

NOTE

When reconnecting the semi-rigid cables, make sure that the cables are connected to the same connectors from which they previously came.

Step 3. Remove the top trim (item 2) using a flat edge driver.

Step 4. Remove the eight TORX T15 screws (item 3) fastening front panel.

Step 5. Gradually push the front panel assembly towards the outside.

Replacement Procedure

Step 1. Reverse the order of the removal procedure.

NOTE

Fasten the semi rigid cable using a torque wrench for replacement.

Figure 6-2

Front Assembly Removal

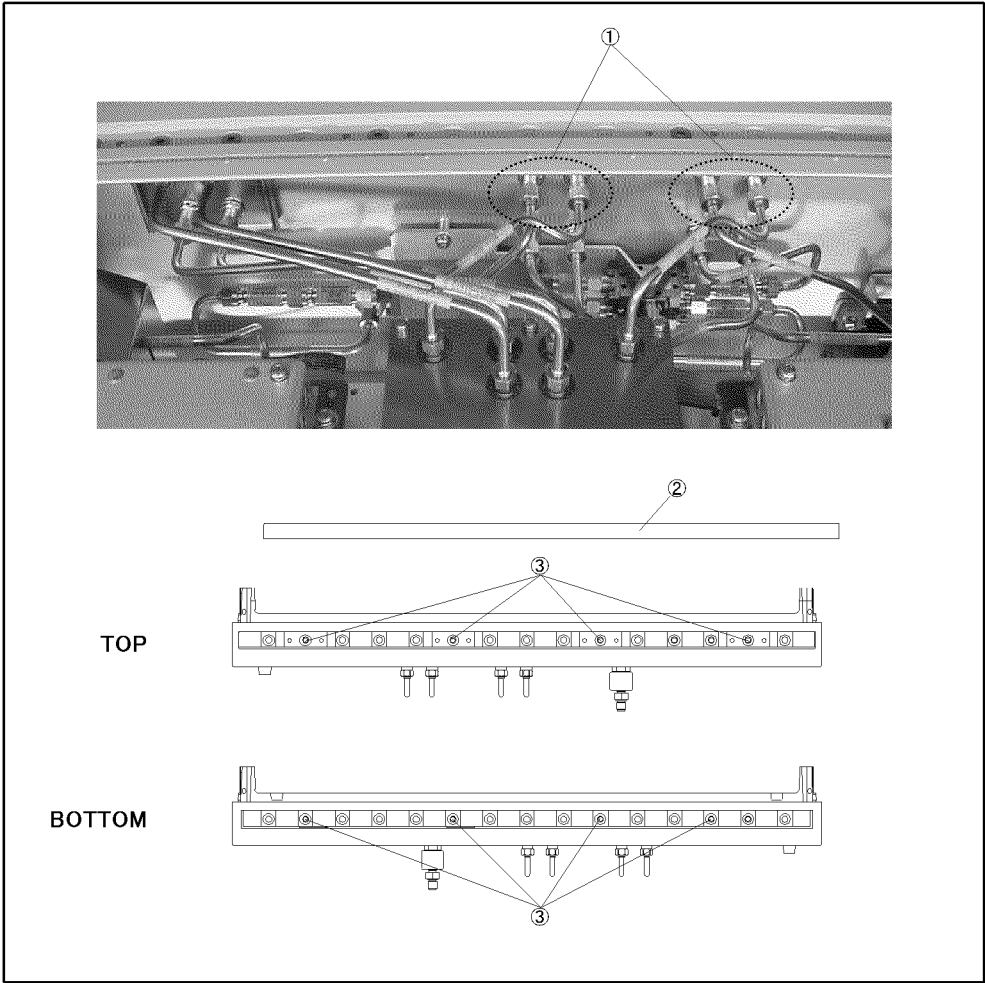

e5053ase1032

Switch Wire Assembly Replacement

Tools required

- TORX screwdriver T8, T10, T15 and T20
- Flat edge screwdriver
- Open-end torque wrench, 5/16 inch (set to 10 in-lb) (for reconnecting SMA connector)

Removal Procedure

Refer to Figure 6-3 for this procedure.

- Step 1.** Remove the outer cover as described in “Outer Cover Removal” on page 80.
- Step 2.** Remove the front panel assembly as described in “Front Assembly Removal” on page 82.
- Step 3.** Release the two switch wire cables from the cable clamp (item 1).
- Step 4.** Disconnect the connectors of switch wire cable (item 2) from the A12.
- Step 5.** Remove the Side trim strip (item 3).
- Step 6.** Remove the two TORX T15 screws (item 4).
- Step 7.** Remove the two TORX T8 screws (item 5).

Replacement Procedure

- Step 1.** Reverse the order of the removal procedure.

Figure 6-3 Switch Wire Assembly Removal

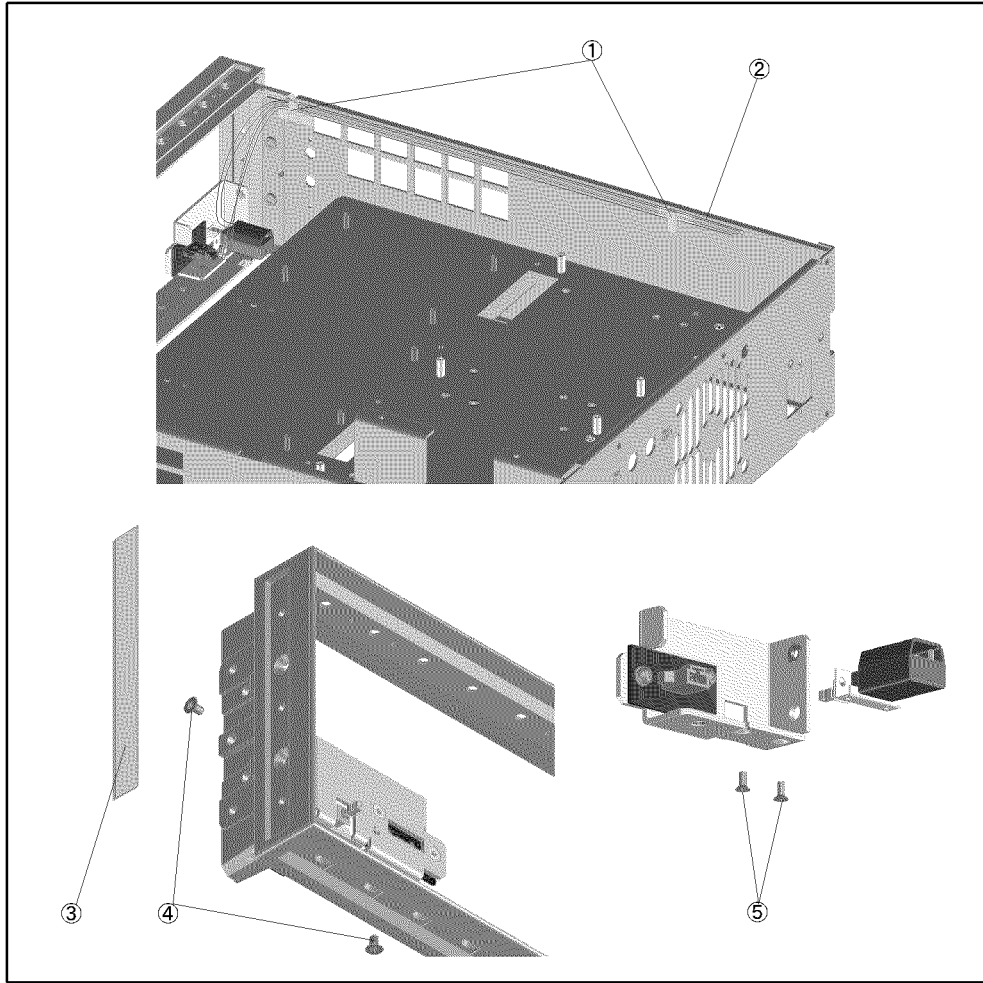

e5053ase1048

RF In Connector Replacement

Tools required

- TORX screwdriver T10, T15 and T20
- Flat edge screwdriver
- Open-end torque wrench, 5/16 inch (set to 10 in-lb) (for reconnecting SMA connector)
- Open-end wrench, 6.5mm (for holding flat part of blocking capacitor)
- Open-end wrench, 1/2 (for reconnecting RF In Connector)

Removal Procedure

Refer to Figure 6-4 for this procedure.

- Step 1.** Remove the outer cover as described in “Outer Cover Removal” on page 80.
- Step 2.** Remove the front panel assembly as described in “Front Assembly Removal” on page 82.
- Step 3.** Remove the semirigid cable (item 2) with holding the flat part of the blocking capacitor (item 1).
- Step 4.** Remove the 1/2 Nut and washer. (item 3, 4).
- Step 5.** Remove the RF In Connector (item 5).

Replacement Procedure

- Step 1.** Reverse the order of the removal procedure.

NOTE

Fasten the semi rigid cable using a torque wrench for replacement.

Fasten the 1/2 Nut with 21 in-lbs torque.

Figure 6-4

RF In Connector Removal

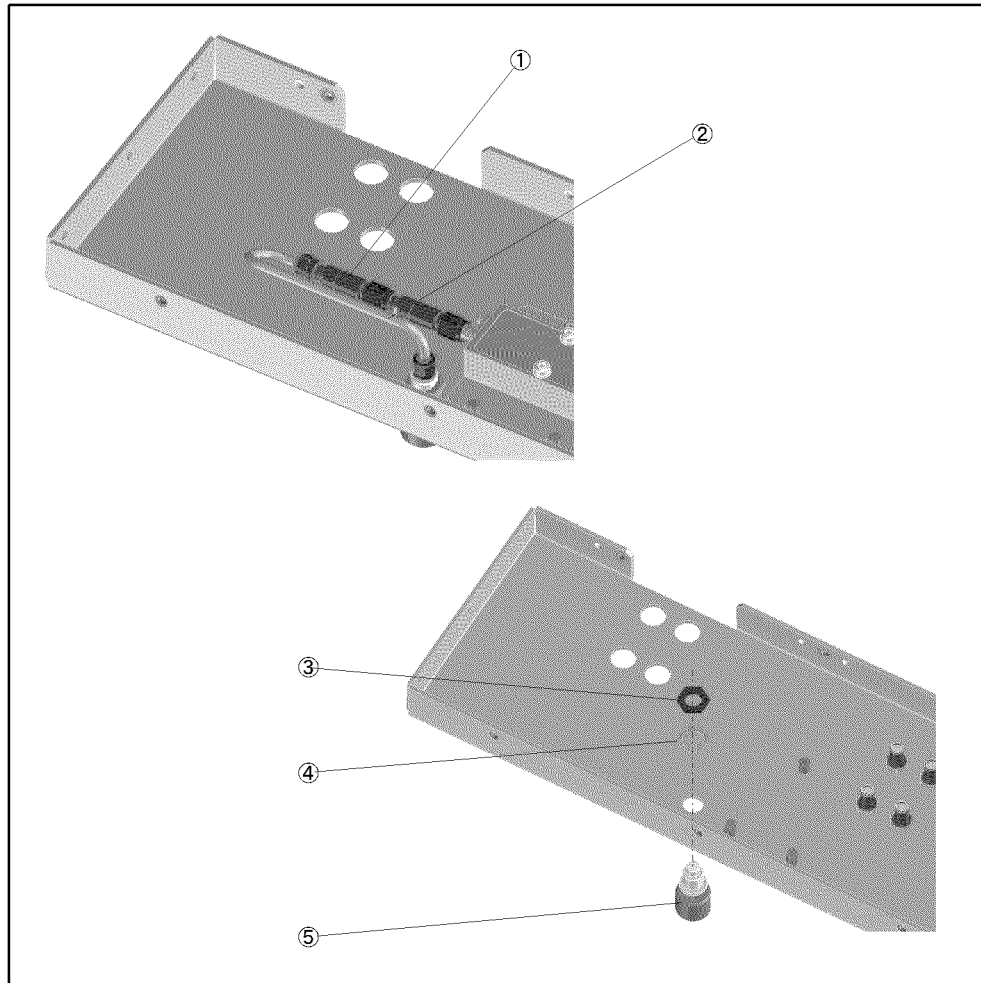

e5053ase1049

Mixer Replacement

Tools required

- TORX screwdriver T10, T15 and T20
- Flat edge screwdriver
- Open-end torque wrench, 5/16 inch (set to 10 in-lb) (for reconnecting SMA connector)
- Open-end wrench, 5.5 mm

Removal Procedure

NOTE The following procedure is common for both mixers. Refer to the items that you intend to remove or replace.

Refer to Figure 6-5 for this procedure.

- Step 1.** Remove the outer cover as described in “Outer Cover Removal” on page 80.
- Step 2.** Remove the front panel assembly as described in “Front Assembly Removal” on page 82.
- Step 3.** Disconnect the four semi-rigid cables (item 1).

NOTE When reconnecting the semi-rigid cables, make sure that the cables are connected to the same connectors from which they previously came.

- Step 4.** Remove the attenuator (item 2).
- Step 5.** Remove the mixer (item 3) by holding the SMA-SMA adaptors’ (item 4) flat part with the 5.5 mm wrench.

NOTE When reconnecting the attenuator, make sure all parts are connected with 10 in-lbs torque and LABEL side up.

When connecting the mixers, make sure that they are attached in proper orientation. The RF port is connected to the power divider, and the LO port is connected to the attenuator.

Replacement Procedure

- Step 1.** Reverse the order of the removal procedure.

NOTE Fasten all SMA connector parts using a torque wrench for replacement.

Figure 6-5

Mixer Removal

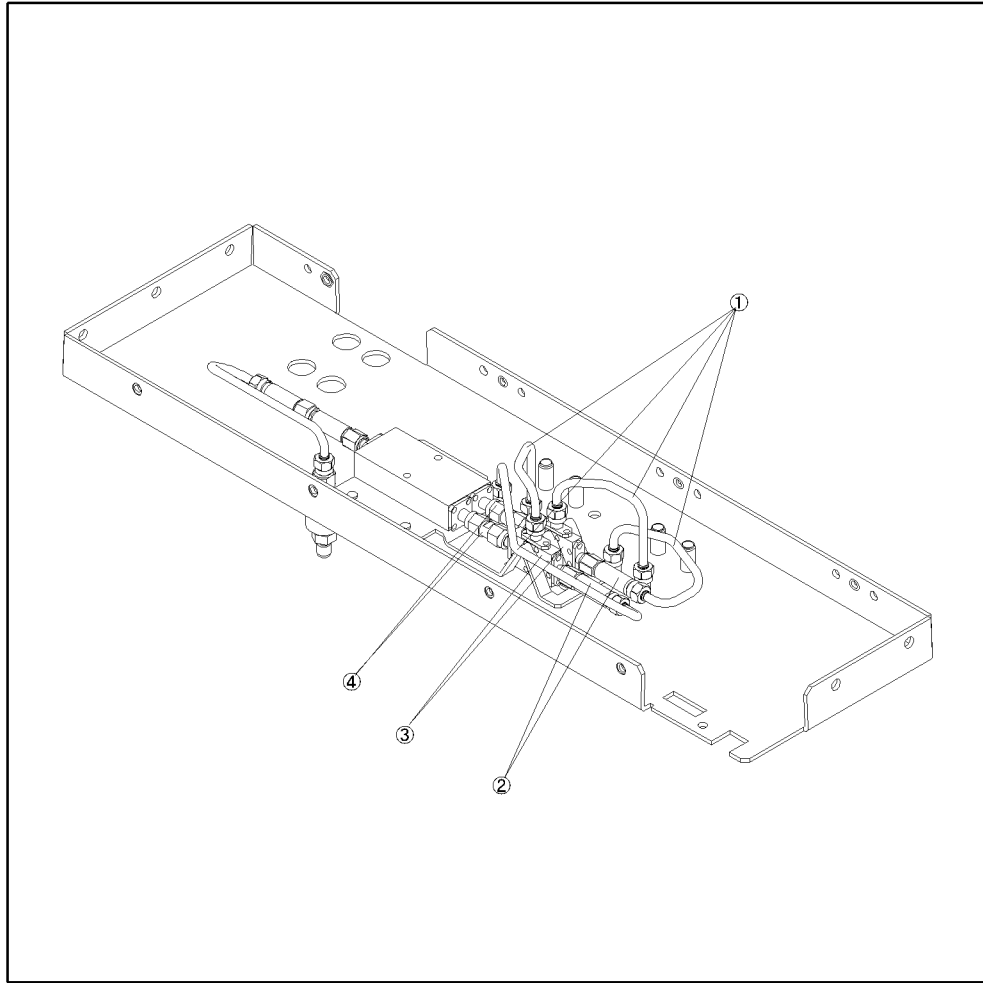

e5053ase1050

Power Divider Replacement

Tools required

- TORX screwdriver T10, T15 and T20
- Flat edge screwdriver
- Open-end torque wrench, 5/16 inch (set to 10 in-lb) (for reconnecting SMA connector)
- Open-end wrench, 5.5 mm and 6.5 mm

Removal Procedure

Refer to Figure 6-6 for this procedure.

- Step 1.** Remove the outer cover as described in “Outer Cover Removal” on page 80.
- Step 2.** Remove the front panel assembly as described in “Front Assembly Removal” on page 82.
- Step 3.** Disconnect the five semi-rigid cables (item 1).

NOTE

When reconnecting the semi-rigid cables, make sure that the cables are connected to the same connectors from which they previously came.

- Step 4.** Remove the TORX T10 screw (item 2) from the Angle (item 3).
- Step 5.** Lift the RF Block part (item 4).
- Step 6.** Remove the blocking capacitor (item 5) by holding the attenuator’s (item 6) flat part with the 6.5 mm wrench.
- Step 7.** Remove the three attenuators (item 6, 7).
- Step 8.** Remove the two mixers (item 8) by holding the SMA-SMA adaptors’ (item 10) flat part with the 5.5 mm wrench.

NOTE

When reconnecting the blocking capacitor and attenuators, make sure all parts are connected with 10 in-lbs torque and LABEL side up.

When connecting the mixers, make sure that they are attached in proper orientation. The RF port is connected to the power divider, and the LO port is connected to the attenuator.

- Step 9.** Remove the two TORX T10 screws (item 9).
- Step 10.** Remove the two SMA-SMA adaptors (item 10).

Replacement Procedure

- Step 1.** Reverse the order of the removal procedure.

NOTE

Fasten all SMA connector parts using a torque wrench for replacement.

Figure 6-6 Power divider Removal

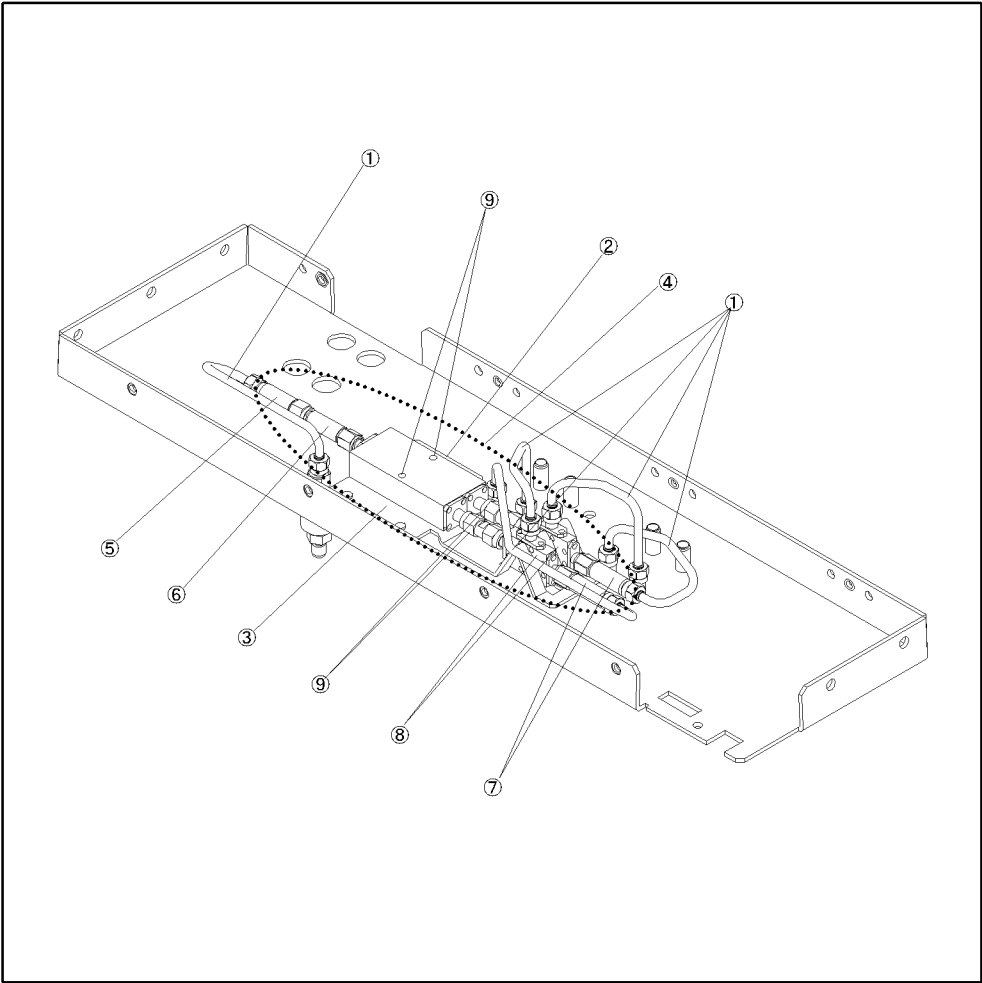

e5053ase1046

SMA Connector Replacement

Tools required

- TORX screwdriver T10, T15 and T20
- Flat edge screwdriver
- Open-end torque wrench, 5/16 inch (set to 10 in-lb) (for reconnecting SMA connector)

Removal Procedure

Refer to Figure 6-7 for this procedure.

- Step 1.** Remove the outer cover as described in “Outer Cover Removal” on page 80.
- Step 2.** Remove the front panel assembly as described in “Front Assembly Removal” on page 82.
- Step 3.** Disconnect the four semi-rigid cables at front side (item 1).
- Step 4.** Disconnect the four semi-rigid cables (item 2).

NOTE

When reconnecting the semi-rigid cables, make sure that the cables are connected to the same connectors from which they previously came.

- Step 5.** Remove the eight 3/8 Nuts (item 3) and washers (item 4).
- Step 6.** Remove the eight SMA f-f connectors (item 5).

Replacement Procedure

- Step 1.** Reverse the order of the removal procedure.

NOTE

Fasten all SMA connector parts using a torque wrench for replacement.

When securing the Nuts to connectors, make sure all parts are secured with 43 in-lbs torque.

Figure 6-7 SMA Connector removal

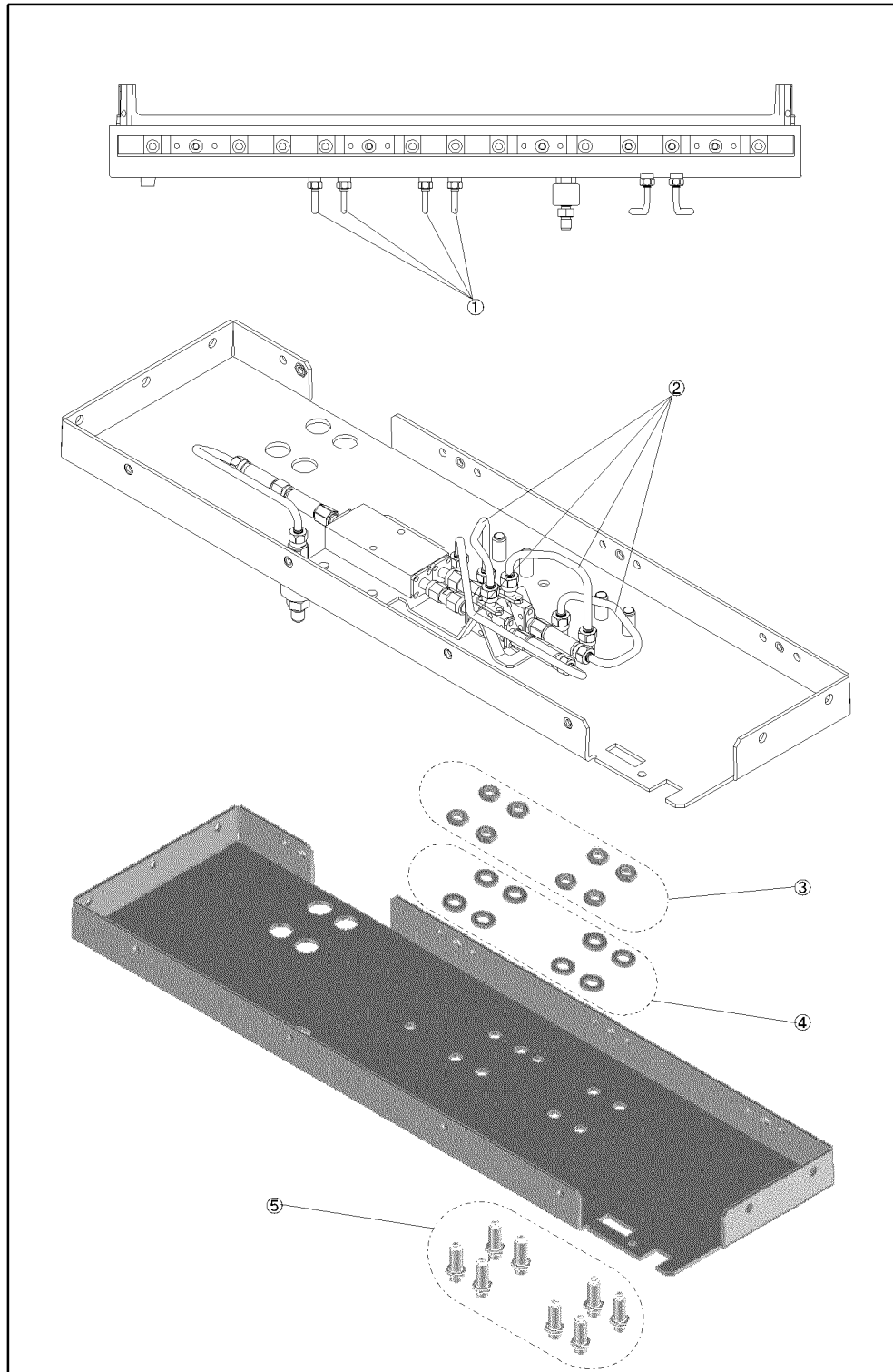

e5053ase1047

Panel Front Replacement

Tools required

- Flat edge screwdriver
- Open-end torque wrench, 5/16 inch (set to 10 in-lb) (for reconnecting SMA connector)

Removal Procedure

Refer to Figure 6-8 for this procedure.

Step 1. Disconnect the four semi-rigid cables (item 1) from the front panel.

NOTE

When reconnecting the semi-rigid cables, make sure that the cables are connected to the same connectors from which they previously came.

Step 2. Peel off the panel front (item 2).

Replacement Procedure

Step 1. Reverse the order of the removal procedure.

NOTE

Fasten all SMA connector parts using a torque wrench for replacement.
Make sure the spring (item 3) is placed on the chassis.

Figure 6-8

Panel Front Removal

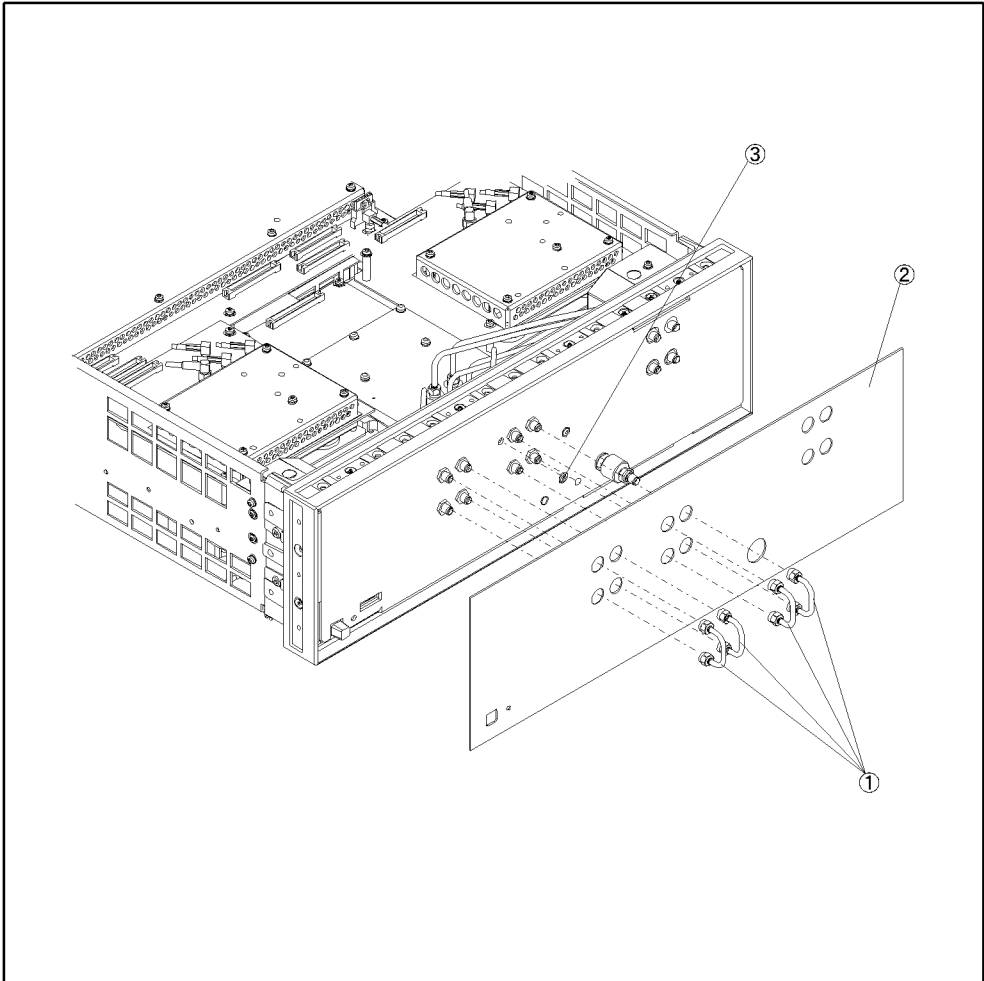

e5053ase1051

A4/A14 YIG PLL Board Replacement

Tools Required

- TORX screwdriver T10, T15 and T20

Removal Procedure

Refer to Figure 6-9 for this procedure.

NOTE

The following procedure is common for the both A4 and A14 assemblies. Refer to the items that you intend to remove or replace.

- Step 1.** Remove the outer cover as described in “Outer Cover Removal” on page 80.
- Step 2.** Turn over the E5053A.
- Step 3.** Disconnect the flat cable (item 1).
- Step 4.** Disconnect the RF cable (item 2).
- Step 5.** Disconnect the flat cable (item 3).
- Step 6.** Disconnect the two semi-rigid cables (item 4).
- Step 7.** Remove the four TORX T10 screws (item 5) fastening the A4/A14 board.
- Step 8.** Lift the A4/A14 board assembly.

Replacement Procedure

- Step 1.** Reverse the order of the removal procedure.

NOTE

Fasten the semi rigid cable using a torque wrench for replacement.

Figure 6-9

A4/A14 YIG PLL Board Removal

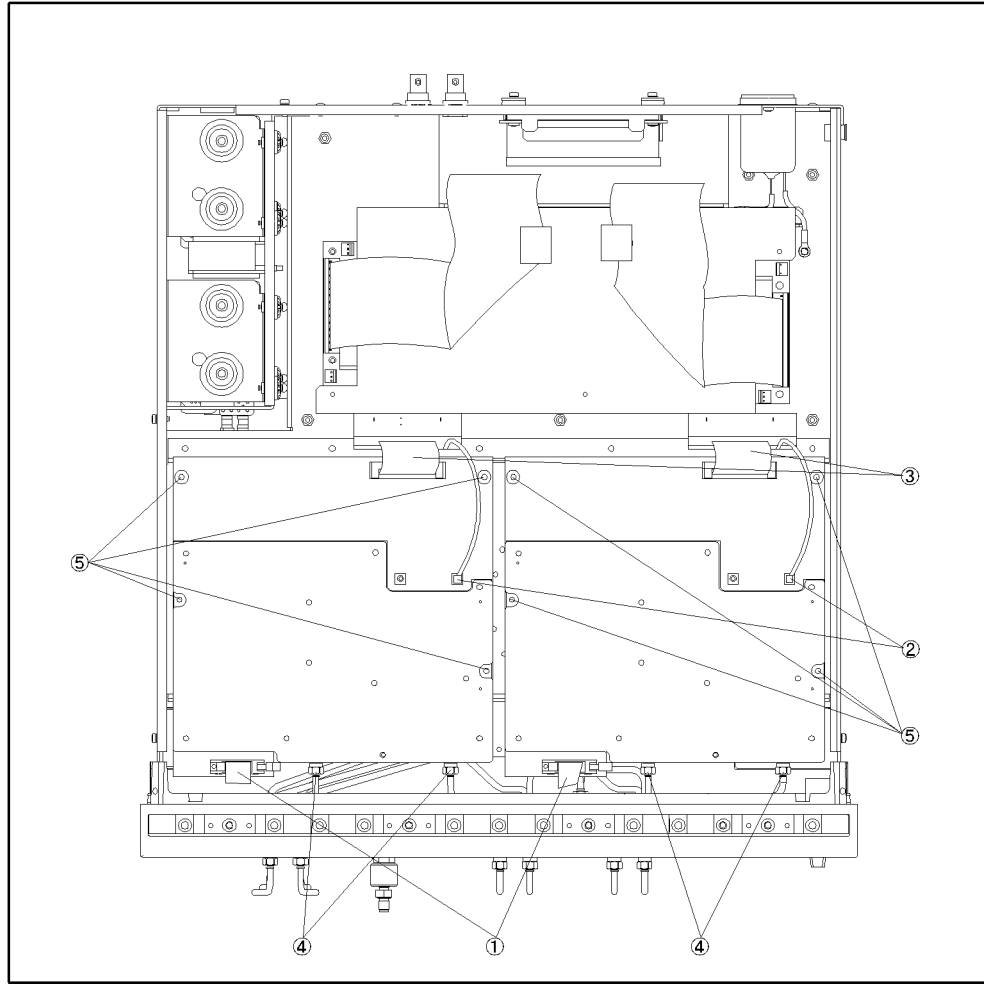

e5053ase1025

A5/A15 Reference PLL Board Replacement

Tools Required

- TORX screwdriver, T10, T15, and T20

Removal procedure

Refer to Figure 6-10 for this procedure.

NOTE

The following procedure is common for the both A5 and A15 assemblies. Refer to the items that you intend to remove or replace.

- Step 1.** Remove the outer cover as described in “Outer Cover Removal” on page 80.
- Step 2.** Disconnect the flat cable (item 1).
- Step 3.** Disconnect the four RF cables (item 2).
- Step 4.** Remove four TORX T10 screws (item 3) fastening the A5/A15 board.
- Step 5.** Lift the A5/A15 board assembly.

Replacement Procedure

- Step 1.** Reverse the order of the removal procedure.

Figure 6-10

A5/A15 Reference PLL Board Removal

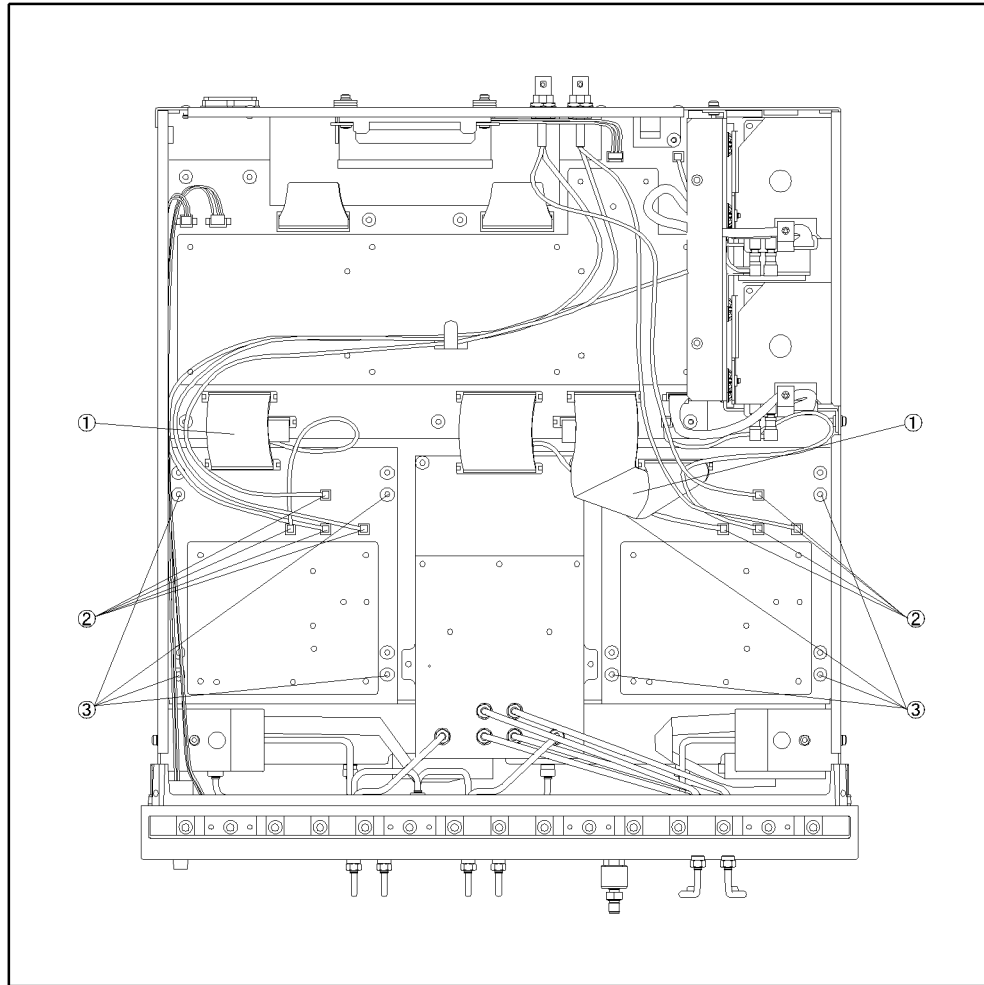

e5053ase1026

A6 Receiver Board Replacement

Tools Required

- TORX screwdriver, T10, T15, and T20
- Open-end torque wrench, 5/16 inch (set to 10 in-lb) (for reconnecting SMA connector)

Removal Procedure

Refer to Figure 6-11 for this procedure.

- Step 1.** Remove the outer cover as described in “Outer Cover Removal” on page 80.
- Step 2.** Disconnect the flat cable (item 1).
- Step 3.** Disconnect the six semi-rigid cables (item 2).
- Step 4.** Remove the four TORX T10 screws (item 3) fastening the A6 board.
- Step 5.** Lift the A6 board assembly.

Replacement Procedure

- Step 1.** Reverse the order of the removal procedure.

NOTE Fasten the semi rigid cable using a torque wrench for replacement.

Figure 6-11 A6 Receiver Board Removal

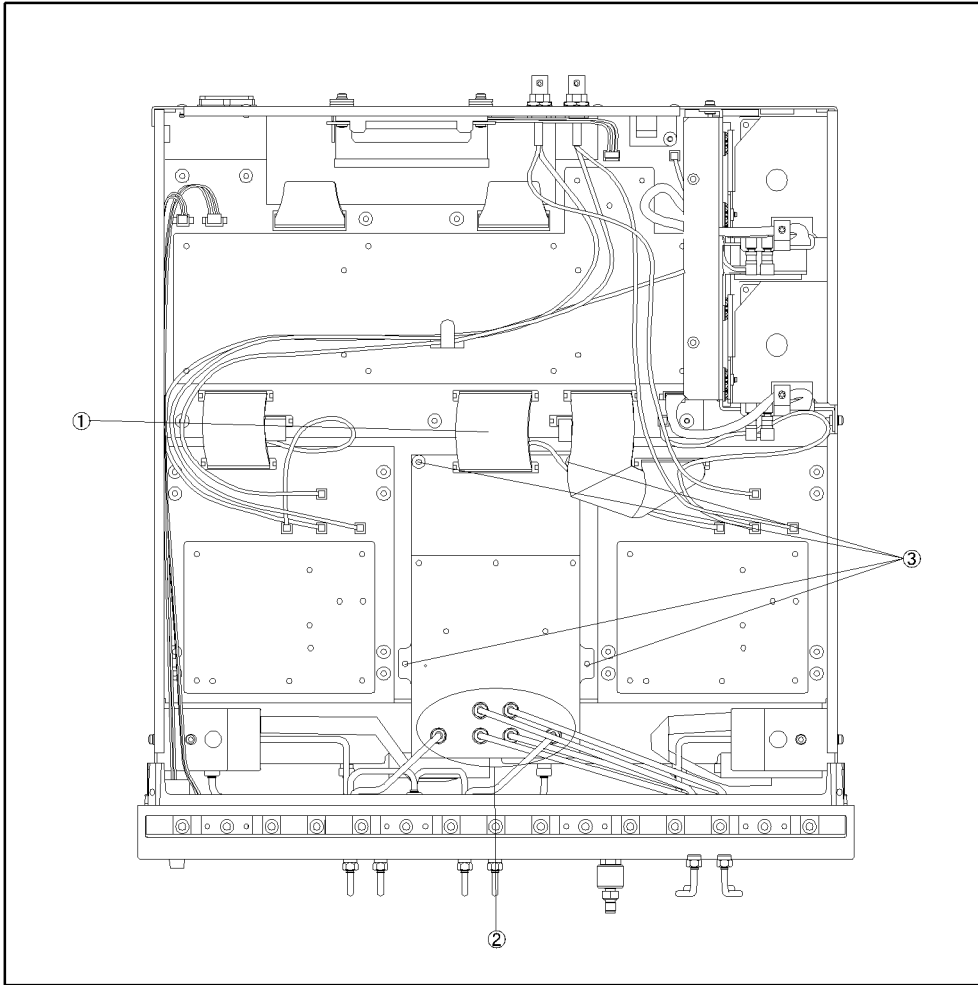

e5053ase1027

A12 PIS DIGIFUL I/F Board Replacement

Tools Required

- TORX screwdriver, T10, T15, and T20

Removal Procedure

Refer to Figure 6-12 for this procedure.

- Step 1.** Remove the outer cover as described in “Outer Cover Removal” on page 80.
- Step 2.** Release the three RF cables from the cable clamp (item 1).
- Step 3.** Disconnect the five flat and two wire cables (item 2, 4).
- Step 4.** Disconnect the two wire cables (item 3, 9).
- Step 5.** Disconnect the three wire cables (item 5, 6).
- Step 6.** Disconnect the two RF cables (item 7, 8).
- Step 7.** Remove the eight TORX T10 screws (item 10) fastening the A12 board.
- Step 8.** Lift the A12 board assembly.

Replacement Procedure

- Step 1.** Reverse the order of the removal procedure.

Figure 6-12 A12 PIS DIGIFUL I/F Board Removal

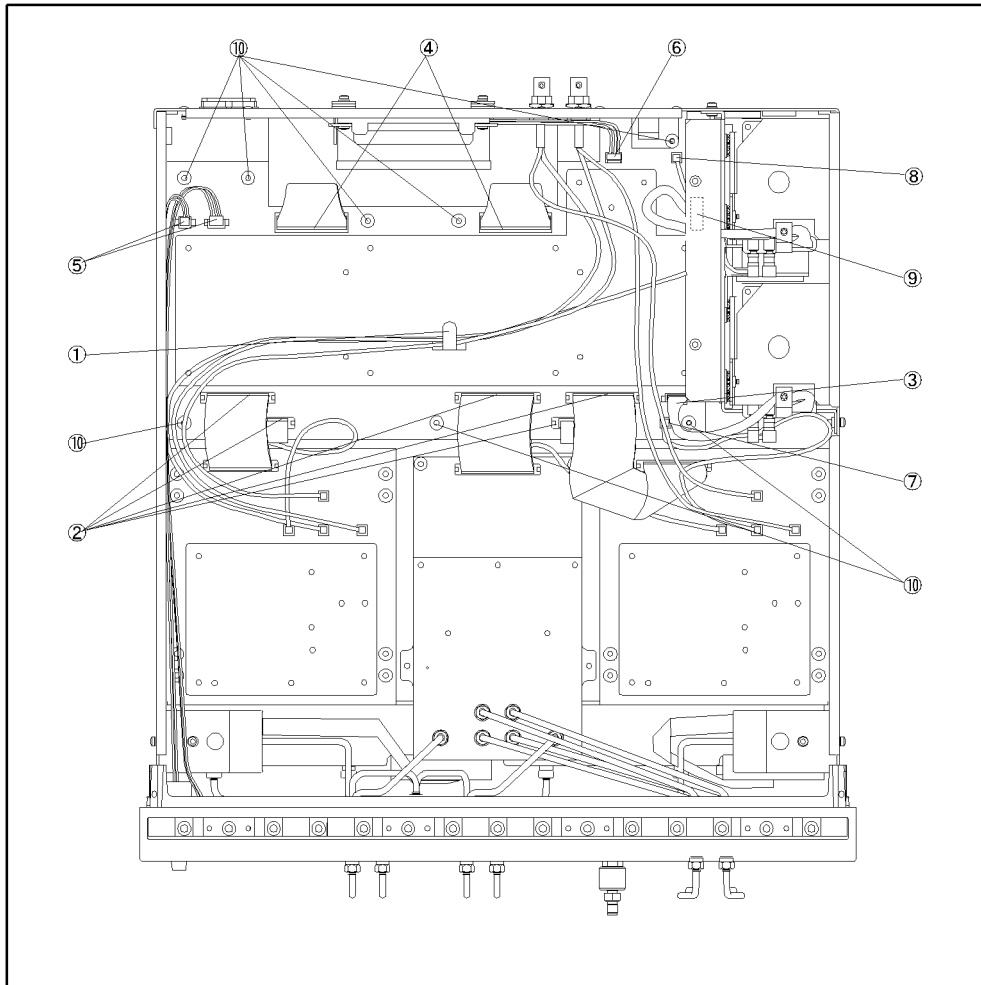

e5053ase1028

OCXO Assembly Replacement

Tools Required

- TORX screwdriver, T10, T15, and T20
- Pozidriv screwdriver, pt size #2 (medium)

Removal Procedure

Refer to Figure 6-13 for this procedure.

NOTE

The following procedure is common for both OCXO assemblies. Refer to the items that you intend to remove or replace.

- Step 1.** Remove the outer cover as described in “Outer Cover Removal” on page 80
- Step 2.** Disconnect the two wire cables (item 1) and four OCXO RF cables (item 2) from the A12 and A5/A15 board.
- Step 3.** Remove the four TORX T10 screws (item 3) and the two TORX T10 flat-pan screws (item 4) fastening the OCXO assembly, and lift the OCXO assembly.
- Step 4.** Remove the three TORX T10 screw fastening the removing OCXO unit (item 5).
- Step 5.** Take the OCXO unit.
- Step 6.** Remove the two TORX T10 screws (item 6) and three pozidriv screws (item 7) fastening the OCXO unit to the case.
- Step 7.** Tilt the OCXO (item 8) and slide it to remove.

Replacement Procedure

- Step 1.** Reverse the order of the removal procedure.

NOTE

Make sure that rubber shock mounts are properly installed. The protruding side is installed inward that is connected to the OCXO unit, and the flat side is installed outward.

Figure 6-13

OCXO Assembly Removal

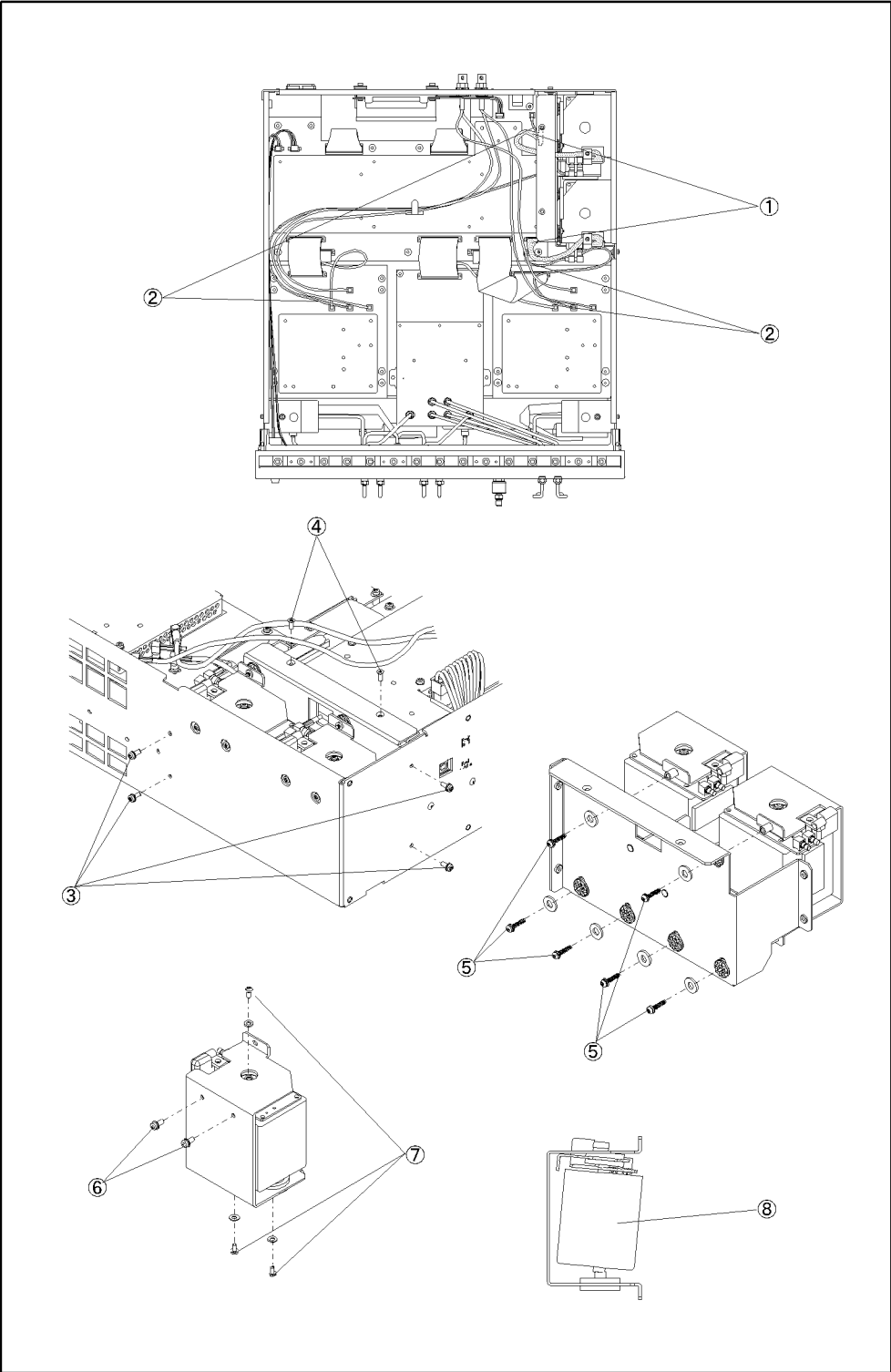

e5053ase1055

YTO (YIG Tuned Oscillator) Assembly Replacement

Tools Required

- TORX screwdriver, T10, T15, and T20
- Open-end torque wrench, 5/16 inch (set to 10 in-lb) (for reconnecting SMA connector)

Removal Procedure

Refer to Figure 6-14 for this procedure.

NOTE

The following procedure is common for both YTO assemblies. Refer to the items that you intend to remove or replace.

- Step 1.** Remove the outer cover as described in “Outer Cover Removal” on page 80
- Step 2.** Remove the TORX T10 screw fastening YTO Case shield, and remove the Case shield. (item 1, 2)
- Step 3.** Disconnect the semi-rigid cable and flat cable’s connector (item 3).
- Step 4.** Remove the two TORX T10 screw fastening YTO Assembly (item 4).
- Step 5.** Lift the YTO Assembly.

Replacement Procedure

- Step 1.** Reverse the order of the removal procedure.

NOTE

Fasten the semi rigid cable using a torque wrench for replacement.

Figure 6-14 YTO Assembly Removal

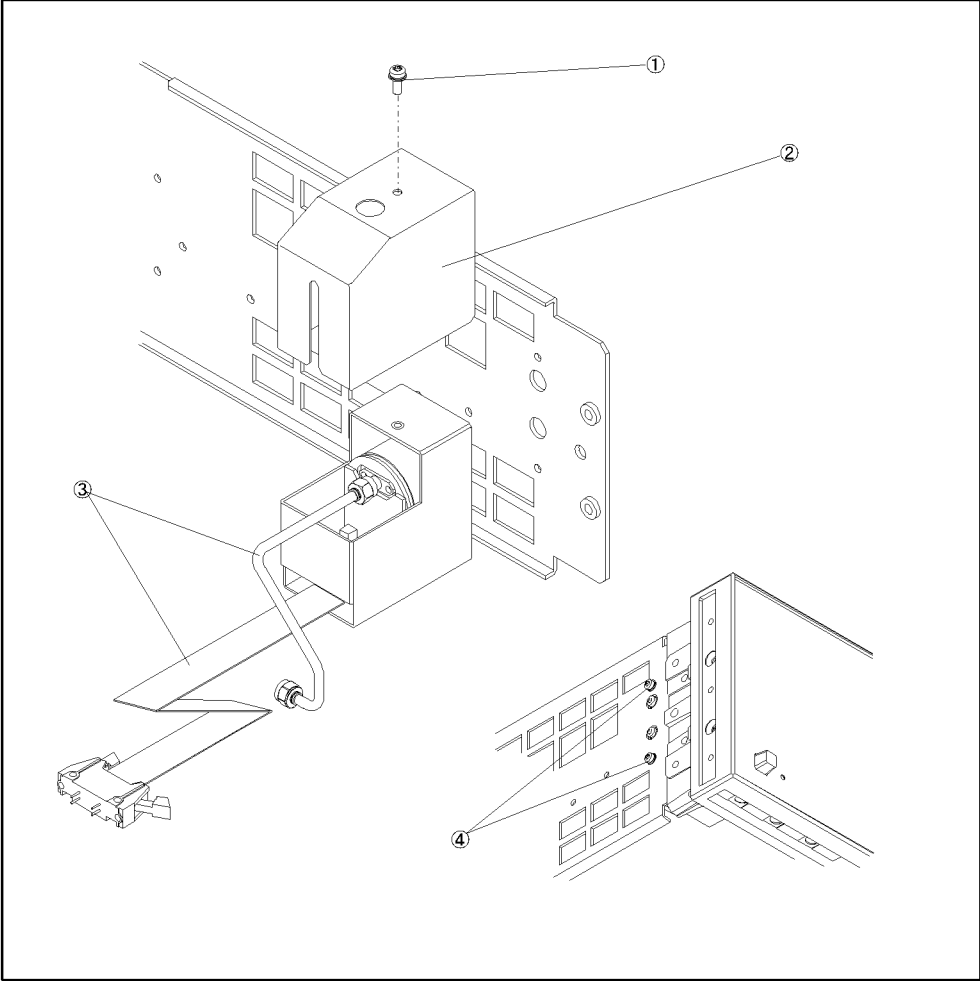

e5053ase1031

Power Supply Assembly Replacement

Tools Required

- TORX screwdriver, T10, T15, and T20
- Flat edge screwdriver

Removal Procedure

Refer to Figure 6-15 for this procedure.

NOTE

The following procedure is common for both Power Supply assemblies. Refer to the items that you intend to remove or replace.

- Step 1.** Remove the outer cover as described in “Outer Cover Removal” on page 80
- Step 2.** Turn over the E5053A.
- Step 3.** Release the two flat cables from the cable clamp (item 1).
- Step 4.** Disconnect the two flat cables (item 2).
- Step 5.** Remove the four TORX T10 screws (item 3).
- Step 6.** Remove the cover (item 4).
- Step 7.** Remove the four TORX T10 screws (item 5).
- Step 8.** Remove the two 5.5 mm STANDOFF (item 5).
- Step 9.** Disconnect the wire cable (item 6).
- Step 10.** Lift the Power Supply Assembly.

Replacement Procedure

- Step 1.** Reverse the order of the removal procedure.

Figure 6-15 Power Supply Assembly Removal

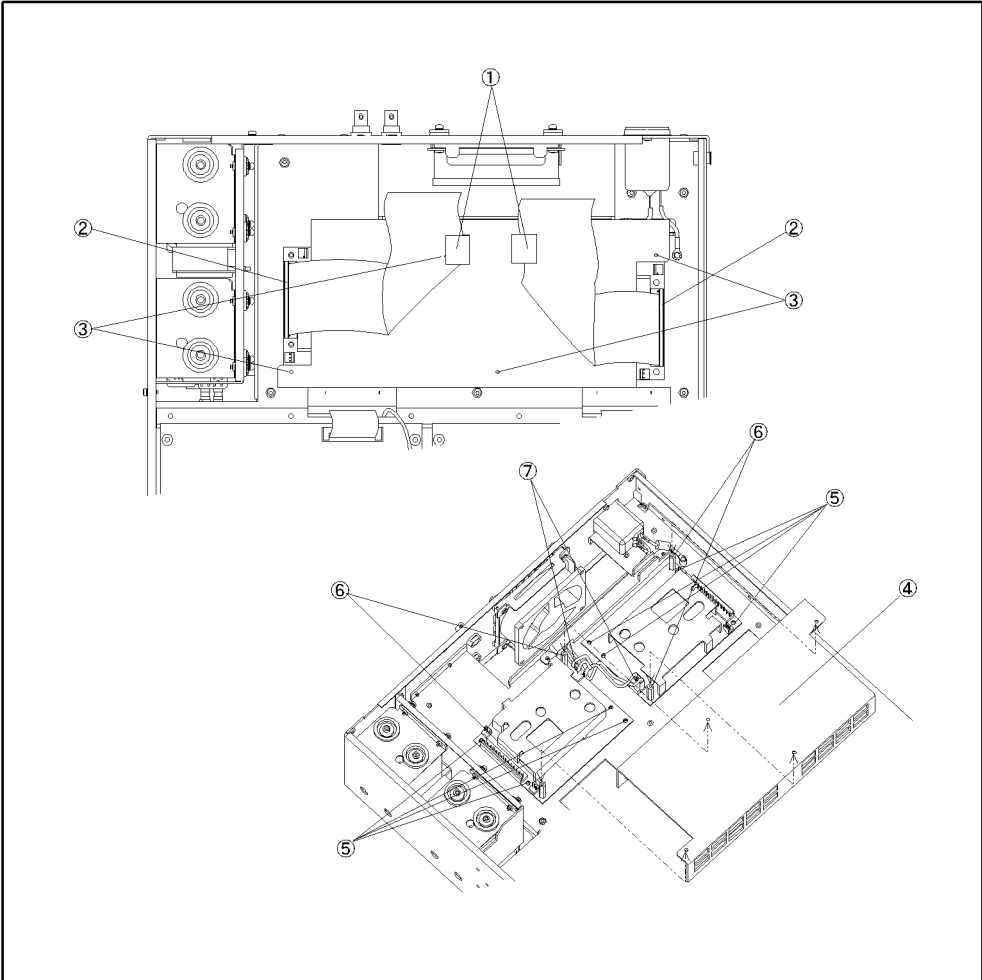

e5053ase1034

Inlet Assembly Replacement

Tools Required

- TORX screwdriver, T10, T15, and T20
- Flat edge screwdriver
- Open-end torque wrench, 5/16 inch (set to 10 in-lb) (for reconnecting SMA connector)

Removal Procedure

Refer to Figure 6-15 for this procedure.

- Step 1.** Remove the outer cover as described in “Outer Cover Removal” on page 80
- Step 2.** Turn over the E5053A.
- Step 3.** Release the cables from the cable clamps (item 1) on the cover.
- Step 4.** Remove the four TORX T10 screws (item 2).
- Step 5.** Remove the cover.
- Step 6.** Remove the two TORX T10 screws (item 3).
- Step 7.** Remove the two TORX T10 screws (item 4).
- Step 8.** Remove a TORX T20 screws (item 5).
- Step 9.** Remove the cover (item 6).
- Step 10.** Disconnect the wire cable (item 7).
- Step 11.** Remove the Inlet Assembly.
- Step 12.** Detach the fuse case (item 8) from the original Inlet Assembly and remove the fuse (item 9).

Replacement Procedure

- Step 1.** Reverse the order of the removal procedure.

NOTE

Do not forget to insert the fuse to the new Inlet Assembly.

Figure 6-16 Inlet Assembly Removal

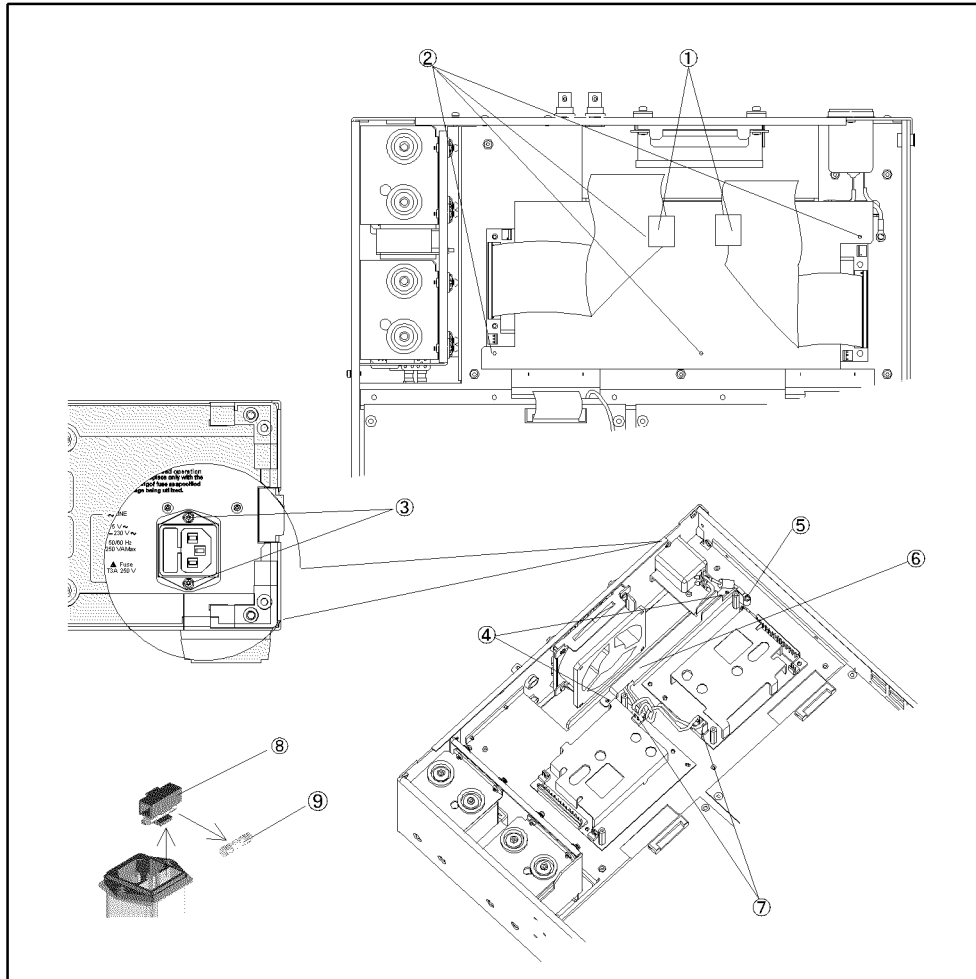

e5053ase1043

Fan Assembly Replacement

Tools Required

- TORX screwdriver, T10, T15, and T20
- Flat edge screwdriver

Removal Procedure

Refer to Figure 6-17 for this procedure.

- Step 1.** Remove the outer cover as described in “Outer Cover Removal” on page 80
- Step 2.** Disconnect the fan cable (item 2).
- Step 3.** Remove four TORX T10 screws (item 1).

Replacement Procedure

- Step 1.** Reverse the order of the removal procedure.

Figure 6-17 Fan Removal

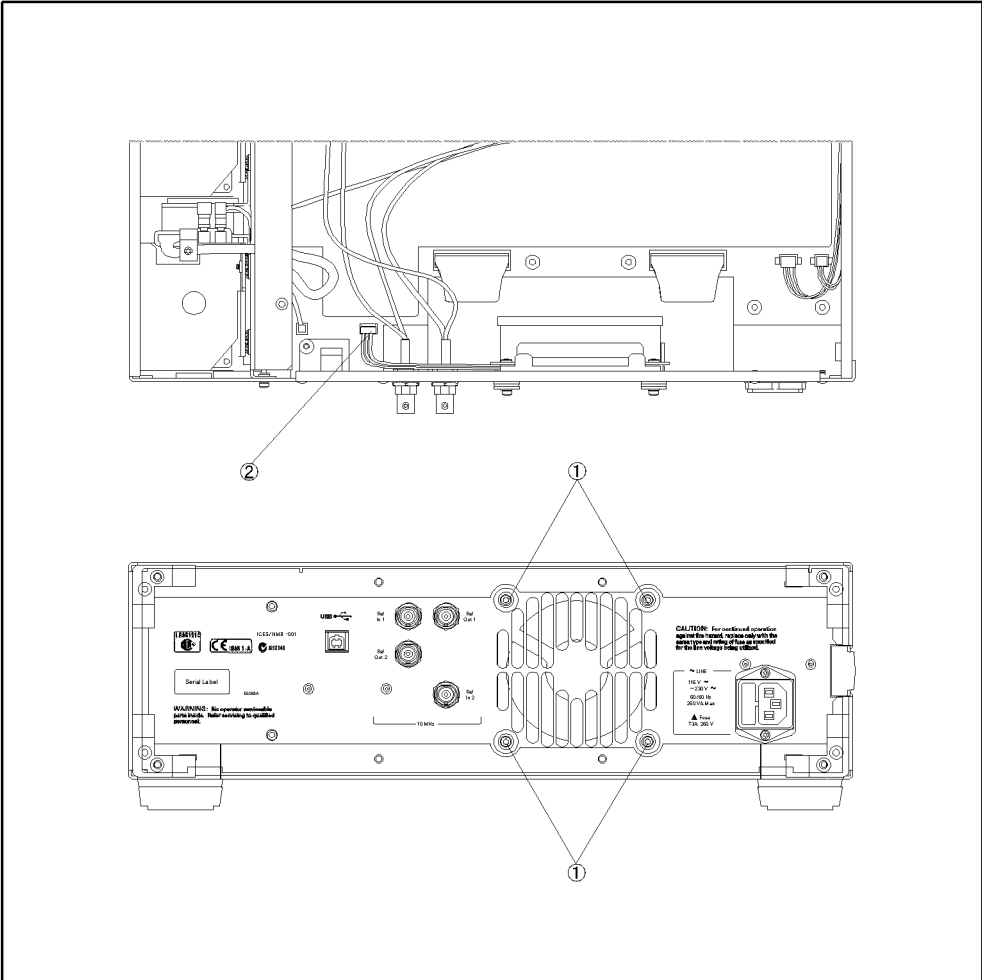

e5053ase1029

Replacement Procedure
Fan Assembly Replacement

7**Post-Repair Procedures**

This chapter lists the procedures required to verify the E5053A operation after an assembly is replaced with a new one.

Post-Repair Procedures

Table 7-1 *Post Repair Procedures* lists the required procedures that must be performed after the replacement of an assembly. These are the recommended minimum procedures to ensure that the replacement is successfully completed.

Table 7-1 Post-Repair Procedures

Replaced Assembly or Part	Required Adjustments Correction Constants (CC)	Verification
A4 YIG PLL	Perform the following required adjustments using “A4 YIG PLL” in Spot Adjustment of the program. Pretune Adjustment Sampler RF Adjustment Output Level Adjustment Mixer IF Adjustment Mixer RF Adjustment	“E5053 Test” on page 40 LOCAL Output Freq Acc Test LOCAL Output Level Acc Test LOCAL Phase Noise Sensitivity Test
A14 YIG PLL	Perform the following required adjustments using “A14 YIG PLL” in Spot Adjustment of the program. Pretune Adjustment Sampler RF Adjustment Output Level Adjustment Mixer IF Adjustment Mixer RF Adjustment	“E5053 Test” on page 40 LOCAL Output Freq Acc Test LOCAL Output Level Acc Test LOCAL Phase Noise Sensitivity Test
A5 REFERENCE PLL	Perform the following required adjustments using “A5 REF PLL” in Spot Adjustment of the program. VCXO Adjustment Sampler RF Adjustment	“E5053 Test” on page 40 LOCAL Output Freq Acc Test LOCAL Output Level Acc Test LOCAL Phase Noise Sensitivity Test
A15 REFERENCE PLL	Perform the following required adjustments using “A15 REF PLL” in Spot Adjustment of the program. VCXO Adjustment Sampler RF Adjustment	“E5053 Test” on page 40 LOCAL Output Freq Acc Test LOCAL Output Level Acc Test LOCAL Phase Noise Sensitivity Test

Table 7-1 Post-Repair Procedures

Replaced Assembly or Part	Required Adjustments Correction Constants (CC)	Verification
A6 RECEIVER	Perform the following required adjustments using “A6 REC” in Spot Adjustment of the program. IF Path Adjustment IF Gain Adjustment Thru Path Adjustment Mixer IF Adjustment Mixer RF Adjustment Level Monitor Adjustment Current Source Adjustment	“E5053 Test” on page 40 LOCAL Phase Noise Sensitivity Test Mixer Bias Output Current Acc Test
A12 PIS DUGIFUL I/F	Perform the following required adjustments using “A12 PIS” in Spot Adjustment of the program. OCXO Adjustment Level Monitor Adjustment	“E5053 Test” on page 40 LOCAL Output Freq Acc Test LOCAL Phase Noise Sensitivity Test
10 MHz OCXO (Ch 1)	Perform the following required adjustments using “OCXO (Ch 1)” in Spot Adjustment of the program. OCXO Adjustment	LOCAL Output Freq Acc Test
10 MHz OCXO (Ch 2)	Perform the following required adjustments using “OCXO (Ch 2)” in Spot Adjustment of the program. OCXO Adjustment	LOCAL Output Freq Acc Test
OSCYIG 5087-7715 (Ch 1)	Perform the following required adjustments using “YIG (Ch 1)” in Spot Adjustment of the program. Pretune Adjustment Sampler RF Adjustment Output Level Adjustment Mixer IF Adjustment Mixer RF Adjustment	“E5053 Test” on page 40 LOCAL Output Freq Acc Test LOCAL Output Level Acc Test LOCAL Phase Noise Sensitivity Test
OSCYIG 5087-7715 (Ch 2)	Perform the following required adjustments using “YIG (Ch 2)” in Spot Adjustment of the program. Pretune Adjustment Sampler RF Adjustment Output Level Adjustment Mixer IF Adjustment Mixer RF Adjustment	“E5053 Test” on page 40 LOCAL Output Freq Acc Test LOCAL Output Level Acc Test LOCAL Phase Noise Sensitivity Test

7. Post-Repair Procedures

Post-Repair Procedures
Post-Repair Procedures

Table 7-1 Post-Repair Procedures

Replaced Assembly or Part	Required Adjustments Correction Constants (CC)	Verification
Mixer 0955-1487 (Ch 1)	Perform the following required adjustments using “RF IN” in Spot Adjustment of the program. Mixer IF Adjustment Mixer RF Adjustment	LOCAL Phase Noise Sensitivity Test
Mixer 0955-1487 (Ch 2)	Perform the following required adjustments using “RF IN” in Spot Adjustment of the program. Mixer IF Adjustment Mixer RF Adjustment	LOCAL Phase Noise Sensitivity Test
Divider 0955-1427	Perform the following required adjustments using “RF IN” in Spot Adjustment of the program. Mixer IF Adjustment Mixer RF Adjustment	LOCAL Phase Noise Sensitivity Test
Blocking Capacitor 11742A	Perform the following required adjustments using “RF IN” in Spot Adjustment of the program. Mixer IF Adjustment Mixer RF Adjustment	LOCAL Phase Noise Sensitivity Test
3dB Attenuator (RF, Ch 1, or Ch 2)	Perform the following required adjustments using “RF IN” in Spot Adjustment of the program. Mixer IF Adjustment Mixer RF Adjustment	LOCAL Phase Noise Sensitivity Test
Power Supply (Ch 1 or Ch 2)	No adjustment needed	“E5053 Test” on page 40

A **Manual Changes**

This appendix contains the information required to adapt this manual to versions or configurations of the E5053A manufactured earlier than the current printing date of this manual. The information in this manual applies directly to E5053A units with the serial number that is printed on the title page of this manual.

Manual Changes

To adapt this manual to your E5053A, refer to Table A-1 and Table A-2.

Table A-1 Manual Changes by Serial Number

Serial Prefix or Number	Make Manual Changes

Table A-2 Manual Changes by Firmware Version

Version	Make Manual Changes

Agilent Technologies uses a two-part, ten-character serial number that is stamped on the serial number plate (Figure A-1). The first five characters are the serial prefix and the last five digits are the suffix.

Figure A-1 Serial Number Plate Example

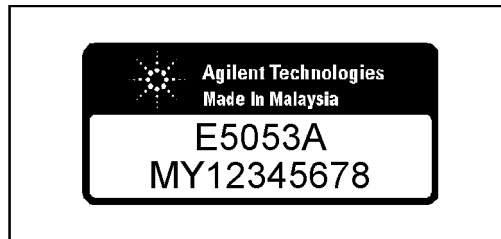

e5053auj1005

B **Power Requirement**

Power Supply and Blown Fuses

Before turning on the E5053A power, check the following important items.

Verification of the power supply

Confirm that the power supplied to the E5053A meets the following requirements:

	Requirements
Voltage	90 to 132 VAC or 198 to 264 VAC *1
Frequency	47 to 63 Hz
Maximum power consumption	250 VA

*1. Switched automatically by the E5053A in conformity to the voltage used.

Verification and connection of power cable

The three-wire power cable attached to the E5053A has one wire serving as a ground. Using this power cable allows the E5053A to be grounded, thereby protecting you against electrical shock from the power outlet.

Step 1. Confirm that the power cable is not damaged.



WARNING NEVER use a power cable showing any sign of damage. Faulty cables can cause electrical shock.

Step 2. Use the supplied cable to connect between the power cable receptacle (Figure B-1 on page 123) on the rear panel of the E5053A and a three-wire power outlet, with the grounding prong firmly connected in the ground slot.

WARNING Use the supplied power cable with grounding wire to securely ground the E5053A.

Figure B-1 shows the power cable options.

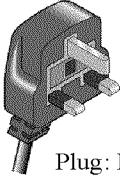
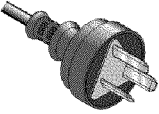
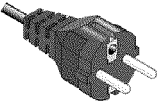
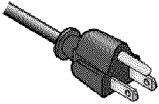
Figure B-1 Power cable options

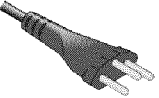
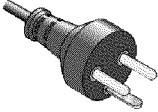
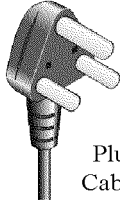
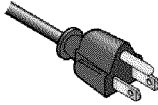
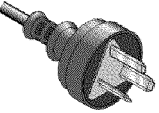
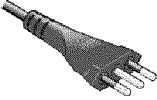
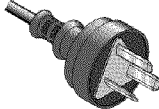
<p>OPTION 900</p>  <p>United Kingdom</p> <p>Plug: BS 1363/A, 250V, 10A Cable: 8120-1351, 8120-8705</p>	<p>OPTION 901</p>  <p>Australia/New Zealand</p> <p>Plug: AS 3112, 250V, 10A Cable: 8120-1369</p>
<p>OPTION 902</p>  <p>Continental Europe</p> <p>Plug: CEE 7 Standard Sheet VII, 250V, 10A Cable: 8120-1689</p>	<p>OPTION 903</p>  <p>U.S./Canada</p> <p>Plug: NEMA 5-15P, 125V, 10A Cable: 8120-1378</p>
<p>OPTION 904</p>  <p>U.S./Canada</p> <p>Plug: NEMA 6-15P, 250V, 6A Cable: 8120-0698</p>	<p>OPTION 906</p>  <p>Switzerland</p> <p>Plug: SEV Type 12, 250V, 10A Cable: 8120-2104</p>
<p>OPTION 912</p>  <p>Denmark</p> <p>Plug: SR 107-2-D, 250V, 10A Cable: 8120-2956</p>	<p>OPTION 917</p>  <p>India/Republic of S. Africa</p> <p>Plug: IEC 83-B1, 250V, 10A Cable: 8120-4211</p>
<p>OPTION 918</p>  <p>Japan</p> <p>Plug: JIS C 8303, 125V, 12A Cable: 8120-4753</p>	<p>OPTION 920</p>  <p>Argentina</p> <p>Plug: Argentine Resolution 63, Annex IV, 250V, 10A Cable: 8120-6870</p>
<p>OPTION 921</p>  <p>Chile</p> <p>Plug: CEI 23-16, 250V, 10A Cable: 8120-6978</p>	<p>OPTION 922</p>  <p>China</p> <p>Plug: GB 1002, 250V, 10A Cable: 8120-8376</p>

NOTE: Each option number includes a 'family' of cords and connectors of various materials and plug body configurations (straight, 90° etc.).

power_e

B. Power Requirement

Power Requirement
Power Supply and Blown Fuses

Blown fuses

If the fuse appears to have blown during operation, this instrument may be subject to failure and must be repaired.

WARNING





Do NOT replace the fuse yourself; doing this may expose you to dangerous electrical shock.

Starting the E5053A

This section describes how to turn ON/OFF the E5053A and how to cut the power supply in an emergency.



Turning ON/OFF the power

Turning ON the power

- Step 1.** Check that the line switch in the lower left part of the front panel is pulled up (). If it is pushed in (), which means the power is OFF, push the standby switch to pull it up ().
- Step 2.** Push the line switch to push it in ().

Turning OFF the power

To turn OFF the E5053A, do the following.

- Push the line switch in the lower left part of the front panel so that the switch pushed in () is pulled up ().

NOTE

To turn OFF the E5053A under normal conditions, press the line switch. **Under normal conditions, never disconnect the power cable to cut the power supply to the power cable receptacle on the rear panel.**

Disconnection from supply source

The power supply of the E5053A is cut off by disconnecting the plug of the power cable (on either AC outlet side or E5053A side). When it is necessary to disconnect the power supply in order to avoid shock hazards, etc., pull out the power cable plug from either the AC outlet side or the E5053A side.

Power Requirement
Starting the E5053A